

This drawing is provisional and subject to our reconfirmation and/or revision without notice.

Coordinates		
記号	X	Y
GM	0	0
DH11	9359	-9359
DH12	-12271	4958

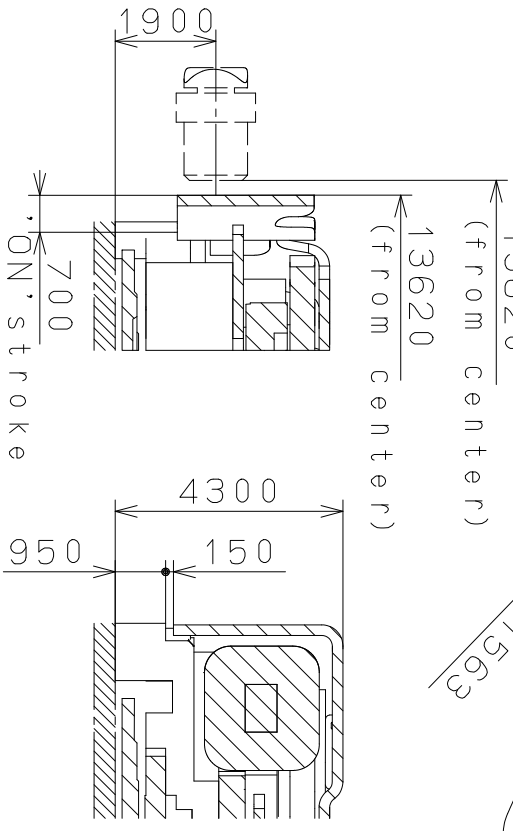
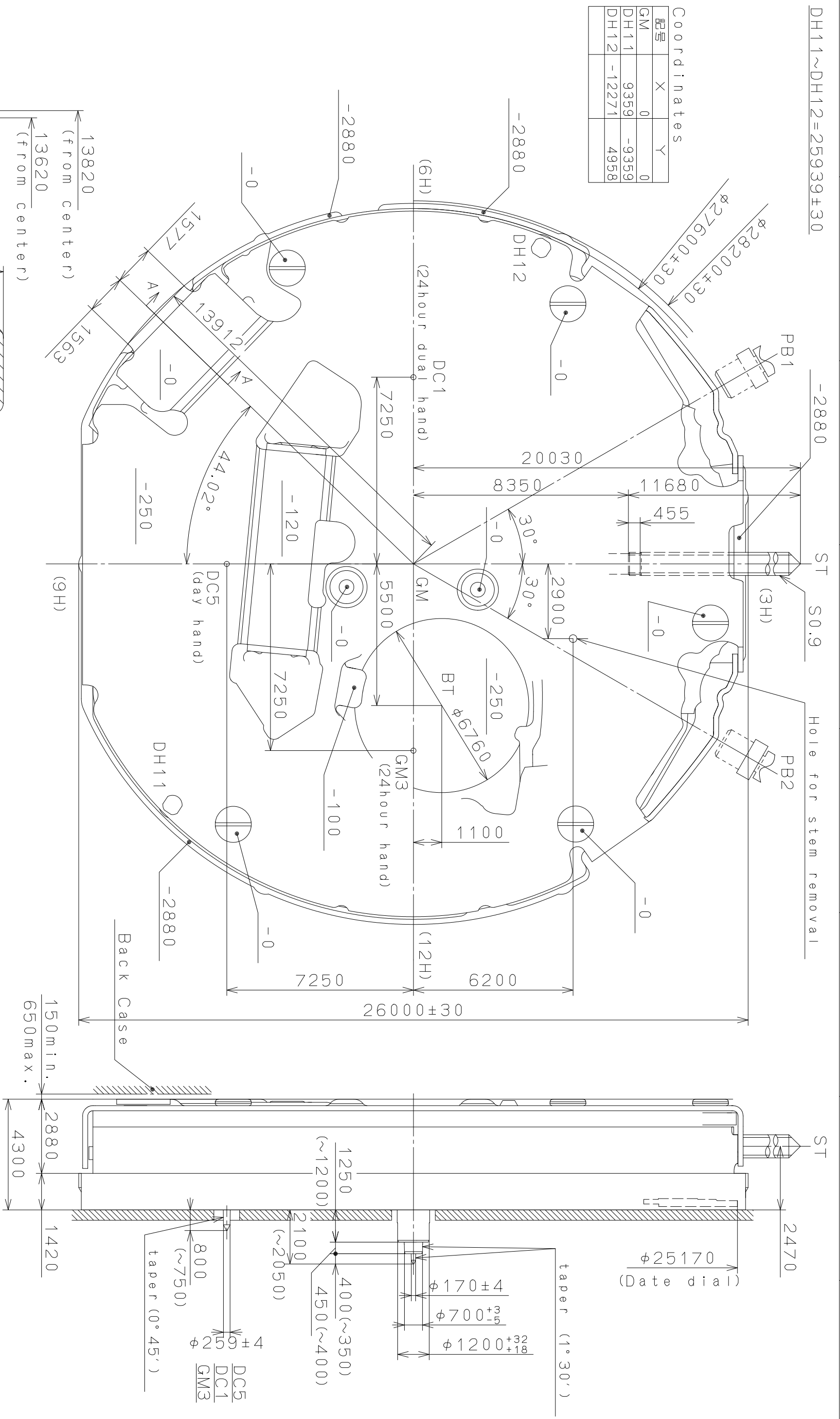

△	Quantity	1/1000 mm	Cal. NO.:	JP15
△	Unit	mm	Parts No.:	
△	Scale	7:1	Name:	Frame for Case
△	Date		Drawing No.:	JP15C0AS
△	Description	Checked		
△	Alterations	Approved		
△	Date			
△	Description	Approved		
△	Date			
△	Description	Checked		
△	Date			
△	Description	Approved		
△	Date			
△	Description	Checked		
△	Date			
△	Description	Approved		
△	Date			
△	Description	Checked		
△	Date			
△	Description	Approved		
△	Date			
△	Description	Checked		
△	Date			
△	Description	Approved		
△	Date			
△	Description	Checked		
△	Date			
△	Description	Approved		
△	Date			
△	Description	Checked		
△	Date			
△	Description	Approved		
△	Date			
△	Description	Checked		
△	Date			
△	Description	Approved		
△	Date			
△	Description	Checked		
△	Date			
△	Description	Approved		
△	Date			
△	Description	Checked		
△	Date			
△	Description	Approved		
△	Date			
△	Description	Checked		
△	Date			
△	Description	Approved		
△	Date			
△	Description	Checked		
△	Date			
△	Description	Approved		
△	Date			
△	Description	Checked		
△	Date			
△	Description	Approved		
△	Date			
△	Description	Checked		
△	Date			
△	Description	Approved		
△	Date			
△	Description	Checked		
△	Date			
△	Description	Approved		
△	Date			
△	Description	Checked		
△	Date			
△	Description	Approved		
△	Date			
△	Description	Checked		
△	Date			
△	Description	Approved		
△	Date			
△	Description	Checked		
△	Date			
△	Description	Approved		
△	Date			
△	Description	Checked		
△	Date			
△	Description	Approved		
△	Date			
△	Description	Checked		
△	Date			
△	Description	Approved		
△	Date			
△	Description	Checked		
△	Date			
△	Description	Approved		
△	Date			
△	Description	Checked		
△	Date			
△	Description	Approved		
△	Date			
△	Description	Checked		
△	Date			
△	Description	Approved		
△	Date			
△	Description	Checked		
△	Date			
△	Description	Approved		
△	Date			
△	Description	Checked		
△	Date			
△	Description	Approved		
△	Date			
△	Description	Checked		
△	Date			
△	Description	Approved		
△	Date			
△	Description	Checked		
△	Date			
△	Description	Approved		
△	Date			
△	Description	Checked		
△	Date			
△	Description	Approved		
△	Date			
△	Description	Checked		
△	Date			
△	Description	Approved		
△	Date			
△	Description	Checked		
△	Date			
△	Description	Approved		
△	Date			
△	Description	Checked		
△	Date			
△	Description	Approved		
△	Date			
△	Description	Checked		
△	Date			
△	Description	Approved		
△	Date			
△	Description	Checked		
△	Date			
△	Description	Approved		
△	Date			
△	Description	Checked		
△	Date			
△	Description	Approved		
△	Date			
△	Description	Checked		
△	Date			
△	Description	Approved		
△	Date			
△	Description	Checked		
△	Date			
△	Description	Approved		
△	Date			
△	Description	Checked		
△	Date			
△	Description	Approved		
△	Date			
△	Description	Checked		
△	Date			
△	Description	Approved		
△	Date			
△	Description	Checked		
△	Date			
△	Description	Approved		
△	Date			
△	Description	Checked		
△	Date			
△	Description	Approved		
△	Date			
△	Description	Checked		
△	Date			
△	Description	Approved		
△	Date			
△	Description	Checked		
△	Date			
△	Description	Approved		
△	Date			
△	Description	Checked		
△	Date			
△	Description	Approved		
△	Date			
△	Description	Checked		
△	Date			
△	Description	Approved		
△	Date			
△	Description	Checked		
△	Date			
△	Description	Approved		
△	Date			
△	Description	Checked		
△	Date			
△	Description	Approved		
△	Date			
△	Description	Checked		
△	Date			
△	Description	Approved		
△	Date			
△	Description	Checked		
△	Date			
△	Description	Approved		
△	Date			
△	Description	Checked		
△	Date			
△	Description	Approved		
△	Date			
△	Description	Checked		
△	Date			
△	Description	Approved		
△	Date			
△	Description	Checked		
△	Date			
△	Description	Approved		
△	Date			
△	Description	Checked		
△	Date			
△	Description	Approved		
△	Date			
△	Description	Checked		
△	Date			
△	Description	Approved		
△	Date			
△	Description	Checked		
△	Date			
△	Description	Approved		
△	Date			
△	Description	Checked		
△	Date			
△	Description	Approved		
△	Date			
△	Description	Checked		
△	Date			
△	Description	Approved		
△	Date			
△	Description	Checked		
△	Date			
△	Description	Approved		
△	Date			
△	Description	Checked		
△	Date			
△	Description	Approved		
△	Date			
△	Description	Checked		
△	Date			
△	Description	Approved		
△	Date			
△	Description	Checked		
△	Date			
△	Description	Approved		
△	Date			
△	Description	Checked		
△	Date			
△	Description	Approved		
△	Date			
△	Description	Checked		
△	Date			
△	Description	Approved		
△	Date			
△	Description	Checked		
△	Date			
△	Description	Approved		
△	Date			
△	Description	Checked		
△	Date			
△	Description	Approved		
△	Date			
△	Description	Checked		
△	Date			
△	Description	Approved		
△	Date			
△	Description	Checked		
△	Date			
△	Description	Approved		
△	Date			
△	Description	Checked		
△	Date			
△	Description	Approved		
△	Date			
△	Description	Checked		
△	Date			
△	Description	Approved		
△	Date			
△	Description	Checked		
△	Date			
△	Description	Approved		
△	Date			
△	Description	Checked		
△	Date			
△	Description	Approved		
△	Date			
△	Description	Checked		
△	Date			
△	Description	Approved		
△	Date			
△	Description	Checked		
△	Date			
△	Description	Approved		
△	Date			
△	Description	Checked		
△	Date			
△	Description	Approved		
△	Date			
△	Description	Checked		
△	Date			
△	Description	Approved		
△	Date			
△	Description	Checked		
△	Date			
△	Description	Approved		
△	Date			
△	Description	Checked		
△	Date			
△	Description	Approved		
△	Date			
△	Description	Checked		
△	Date			
△	Description	Approved		
△	Date			
△	Description	Checked		
△	Date			
△	Description	Approved		
△	Date			
△	Description	Checked		
△	Date			
△	Description	Approved		
△	Date			
△	Description	Checked		
△	Date			
△	Description	Approved		
△	Date			

This drawing is provisional and subject to our reconfirmation and/or revision without notice.

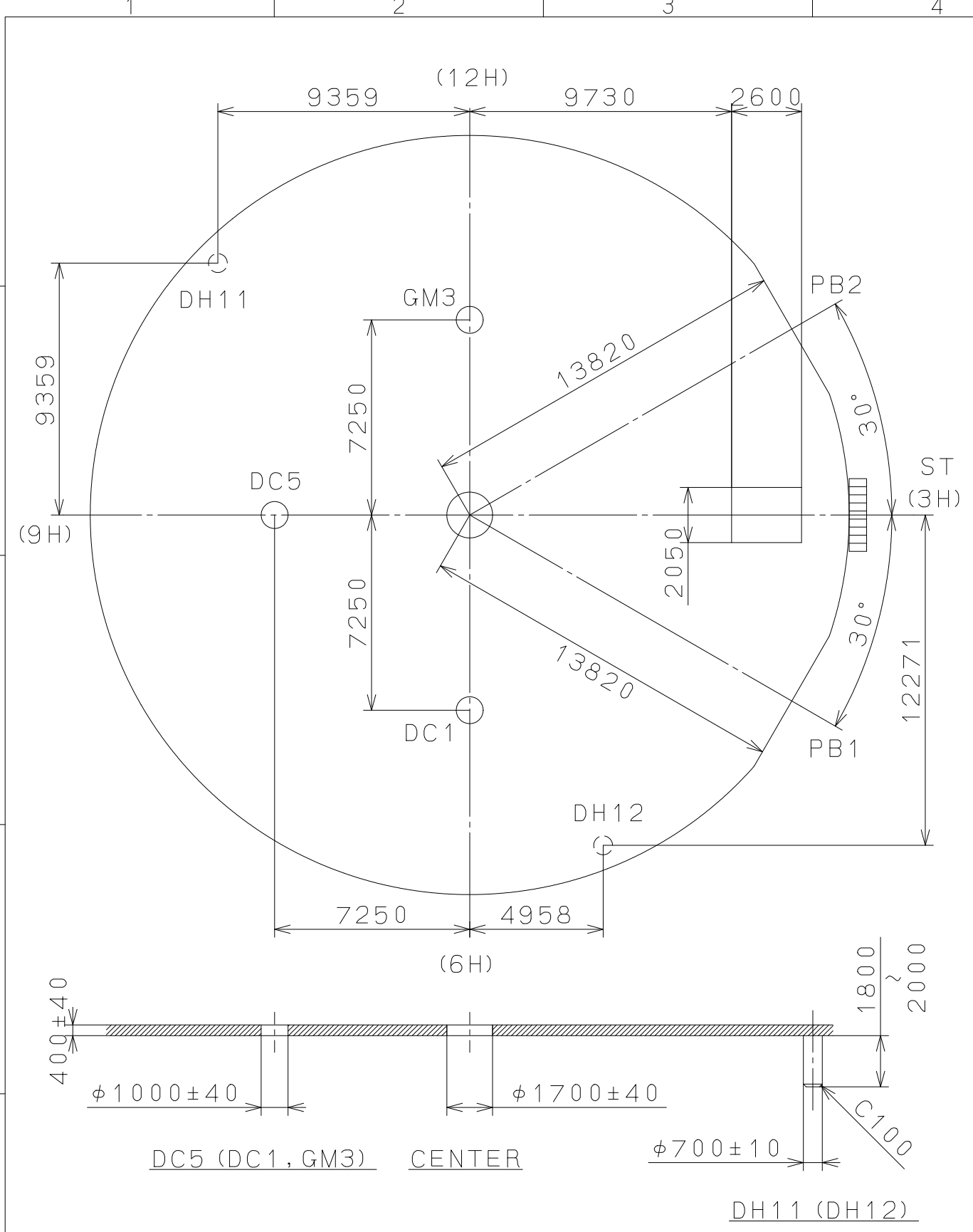

△			Quantity		Cal.NO.:
△			Unit	1/1000 <sub>mm</sub>	JP15-00C
△			Scale	5 : 1	Parts No.:
△			Date		
△			Drawn		
Mark	Date	Description	Appr.	Checked	Name:
		Alterations	Approved	N. Suzuki	Indications for Dial
Material					Drawing No.: JP15D0AS
Heat Treatment			General Tolerances	<b>MIYOTA</b> CITIZEN WATCH CO., LTD. TOKYO, JAPAN	
Hardness			Dimensions		
Plating			Angles		

2006/12/25 (07:50:10)

This drawing is provisional and subject to our reconfirmation and/or revision without notice.

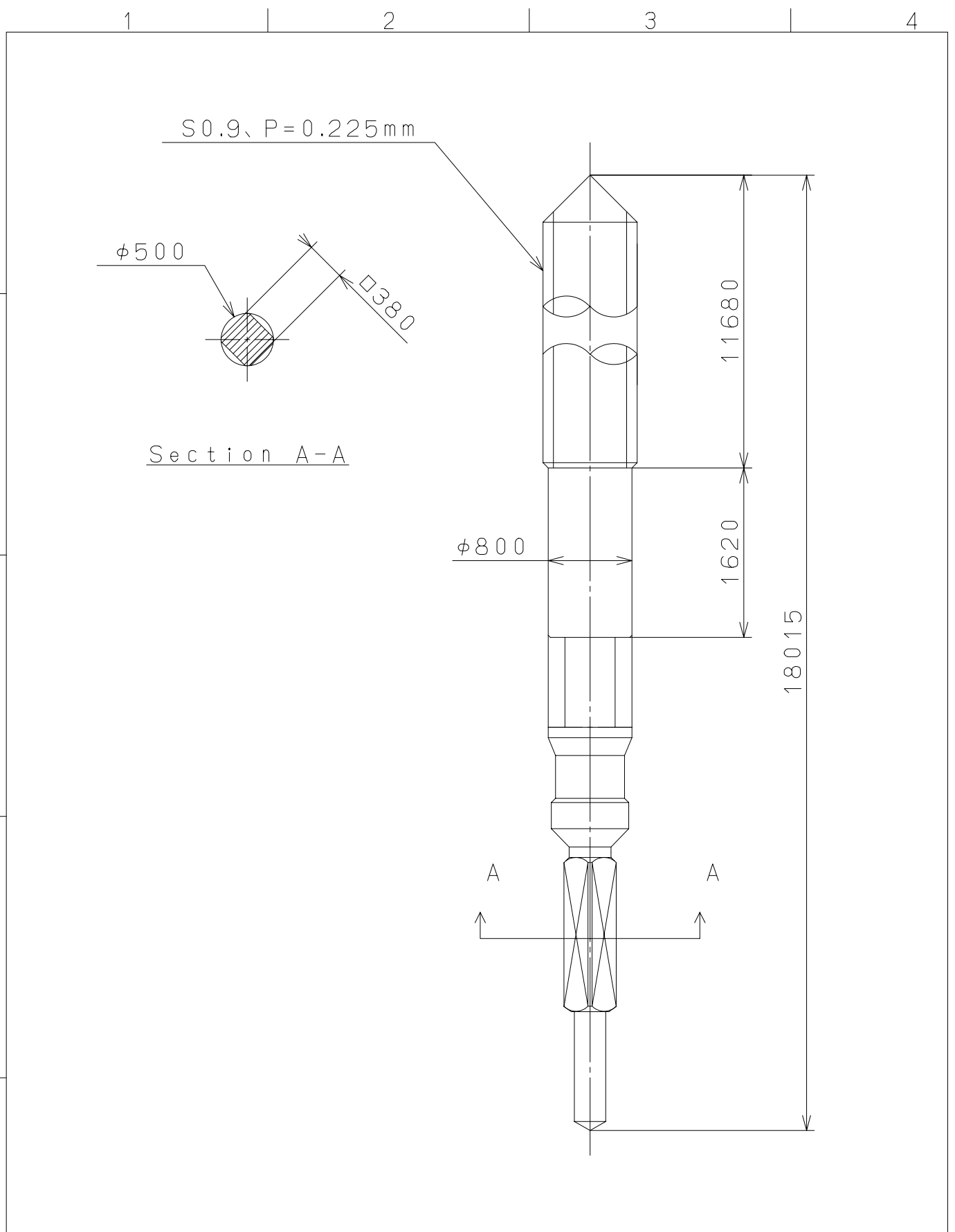

△5			Quantity		Cal.NO.:
△4			Unit	1 / 1000 mm	
△3			Scale	20 / 1	Parts No.:
△2			Date		065-505
△1			Drawn		
Mark	Date	Description	Appr.	Checked	Name:
		Alterations		Approved	SETTING STEM
Material					Drawing No.: 5050S000
Heat Treatment			General	Tolerances	<b>MIYOTA</b>
Hardness			Dimensions		
Plating			Angles		
					CITIZEN WATCH CO., LTD. TOKYO, JAPAN