

# RONDA normtech 700 & 6000

Lange Batterielaufzeit und spezielle Funktionen

*Kaliber 751 – 5½'''*

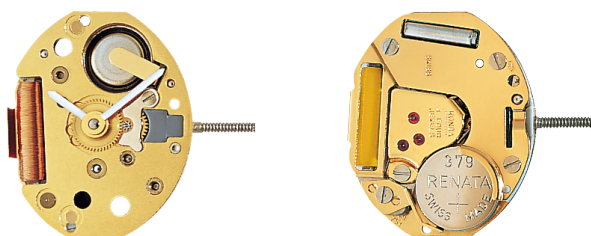

## Produktespezifikationen

Analog-Quarzuhrwerk

Linie normtech

Kaliber 751

Werkgrösse 5½'''

Version Swiss Made 4 Steine / vergoldet  
Swiss Parts 1 Steine / vernickelt

Standard Batterie Laufzeit 7 Jahre

Zeigerwerkhöhe 1

## Spezielle Merkmale

- Reparierbares Metalluhrwerk
- Sehr lange Batterielaufzeit
- Energieeinsparungs-Funktion bei gezogener Stellwelle:  
Reduktion des Stromverbrauchs um ca. 70%
- Viele hohe Zeigerwerke erhältlich

**Funktionen**

– 2 Zeiger

**Technische Spezifikationen**

Gesamtabmessung	13.00 mm
Werksitz	13.00 mm
Werkhöhe	2.50 mm
Höhe über Standard Batterie	2.65 mm
Höhe der Werkauflage	0.40 mm
Stellwellenhöhe	1.00 mm
Stellwellen-Weg	0.40 mm
Kraft für das Eindrücken der Stellwelle mit geschraubter Krone	– / – N
Stellwelle Gewinde	0.90 mm
Standard Batterie	379
Standard Batterie Laufzeit	7 Jahre
Batterie-Spannung	1.5 V
Stromverbrauch – typisch	0.24 µA
Stromverbrauch – max.	0.3 µA
Drehmoment Minute – typisch	30 µNm
Betriebstemperatur	0 - 50 °C
Momentaner Gang	-10/ +20 Sek/Monat
Magnetfeldabschirmung	18.8 Oe
Schockresistenz	NIHS 91-10



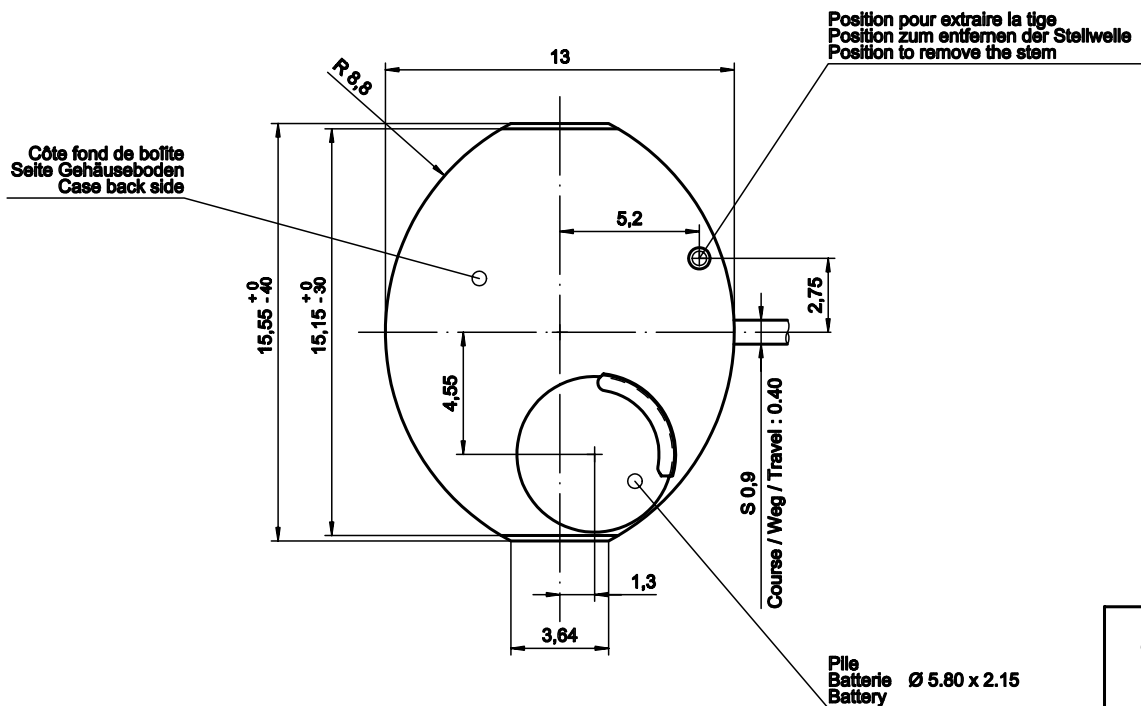
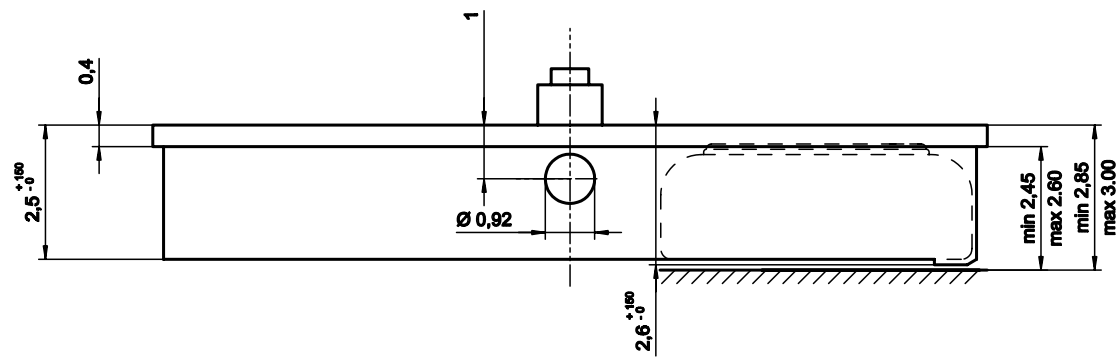

Sécurité entre aiguille seconde et verre : min 0.30 mm  
 Sicherheit zwischen Sekundenzeiger und Glas : min 0.30 mm  
 Security between second hand and glass : min 0.30 mm

Le cadran doit être maintenu en hauteur par la boîte.  
 Das Zifferblatt muss in der Höhe vom Gehäuse festgehalten werden.  
 The dial must be held in the height by the case.

<b>Cage</b> <b>Uhrwerkgestell</b> <b>Frame</b>	<b>5½<sup>mm</sup></b>	Issued	04 Okt 1985	nt
		Modified	11. Dez. 2006	cm
		Released	AA —	
		Tolerance	+/- 20 µm	
		Scale	10 : 1 (5 : 1) (A3H)	
<b>RONDA</b>	<b>751, 751E, 753</b>	Sous réserve de modifications Änderungen vorbehalten Modifications reserved		
		No. <b>5000.234</b>	<b>16</b>	



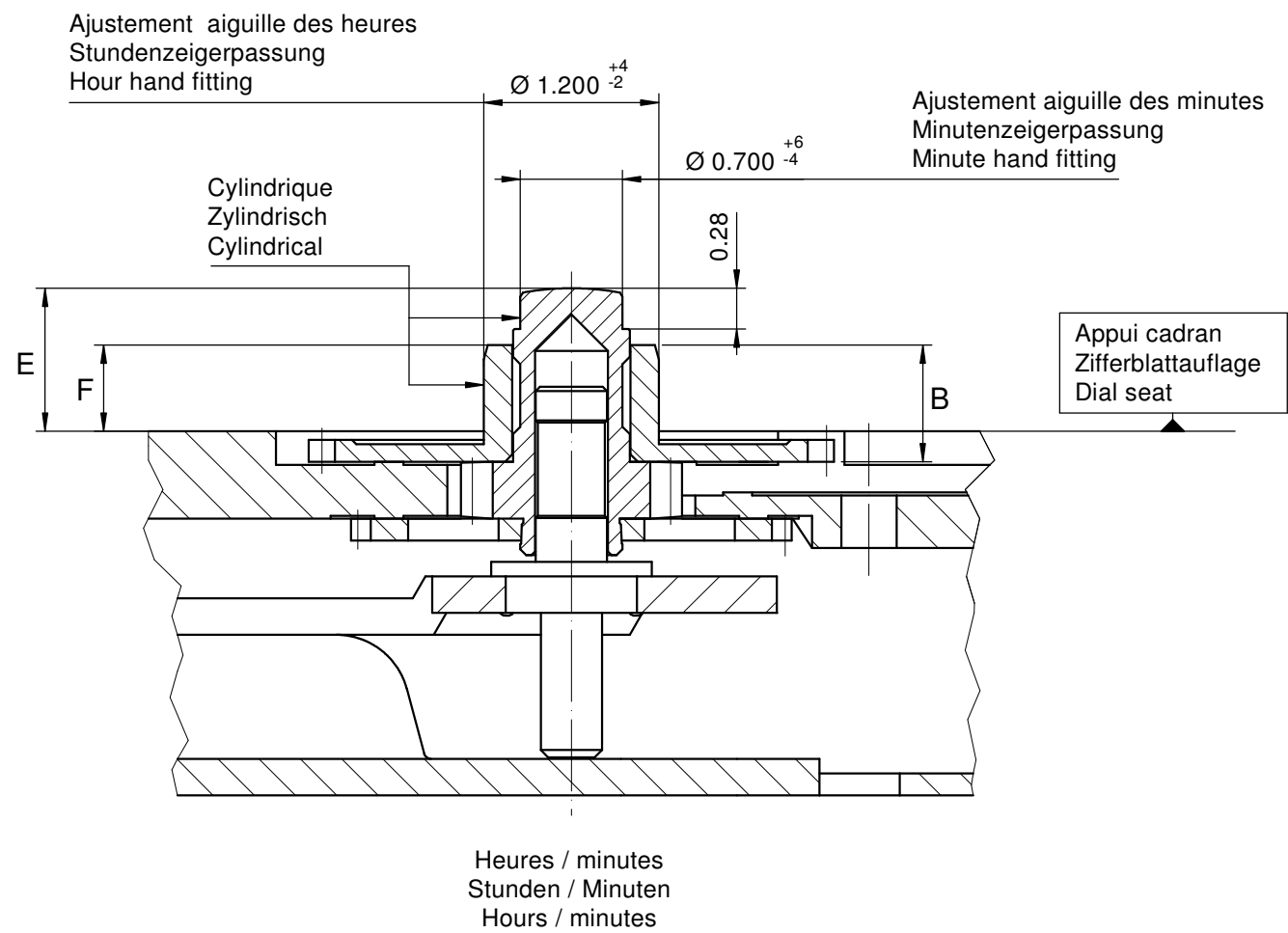

Aiguillage no Zeigerwerkhöhe Nr. Hand fitting height No	Dépassement Höhe über Zifferblattaufgabe Height over dial seat			Longueur Länge Length		Epaisseur max. (peinture comprise) Max. Dicke (inkl. Farbe) Max. thickness (paint included)		
	Chaussée Minutenrohr Cannon-pinion	Roue des heures Stundenrad Hour wheel		Roue des heures Stundenrad Hour wheel		Cadran Zifferblatt Dial		Aiguilles Zeiger Hands
						Sous l'aiguille des minutes Unter Minutenzeiger Under minute hand	Sous l'aiguille des heures Unter Stundenzeiger Under hour hand	
E	F		B					
0	0.95	0.60		0.80		0.50	0.30	0.15
1	1.10	0.75		0.95		0.65	0.40	0.15
2	1.30	0.95		1.15		0.85	0.60	0.15
3	1.80	1.35		1.57		1.35	1.00	0.15
4	2.70	2.35		2.55		2.25	2.00	0.15
5	3.30	2.95		3.15		2.85	2.60	0.15

	Aig. des minutes Minutenzeiger Minute hand	Aig. des heures Stundenzeiger Hour hand	Lors de la pose d'aiguilles, le mouvement doit être soutenu. Beim Zeigersetzen muss das Werk abgestützt werden. The movement needs to be supported for hand setting.
mg max.	30	30	Masse / Masse / Weight *
µNm max.	0.14	0.14	Balourd / Unwucht / Unbalance *
gmm <sup>2</sup> max.	-	-	Inertie / Massenträgheit / Inertia *
N max.	40	40	Force de chassage / Aufpresskraft / Force

<b>Aiguillages</b> <b>Zeigerwerkhöhen 5½", 6¾ x 8"</b> <b>Hand fitting heights</b>		Issued	18 Feb 2001	mk
		Modified	06 Jan 2016 ÄA 13573	dh
		Released	Yes	
		Tolerance	µm	
		Scale	20 : 1 (A3H)	
RONDA	751, 756, 762, 762E	Sous réserve de modifications Änderungen vorbehalten Modifications reserved		
		No.	3316.002	20

\* En cas de données différentes, veuillez contacter le service après-vente

\* Bei abweichenden Werten, bitte technischen Kundendienst anfragen

\* In case of different values, please contact the customer service

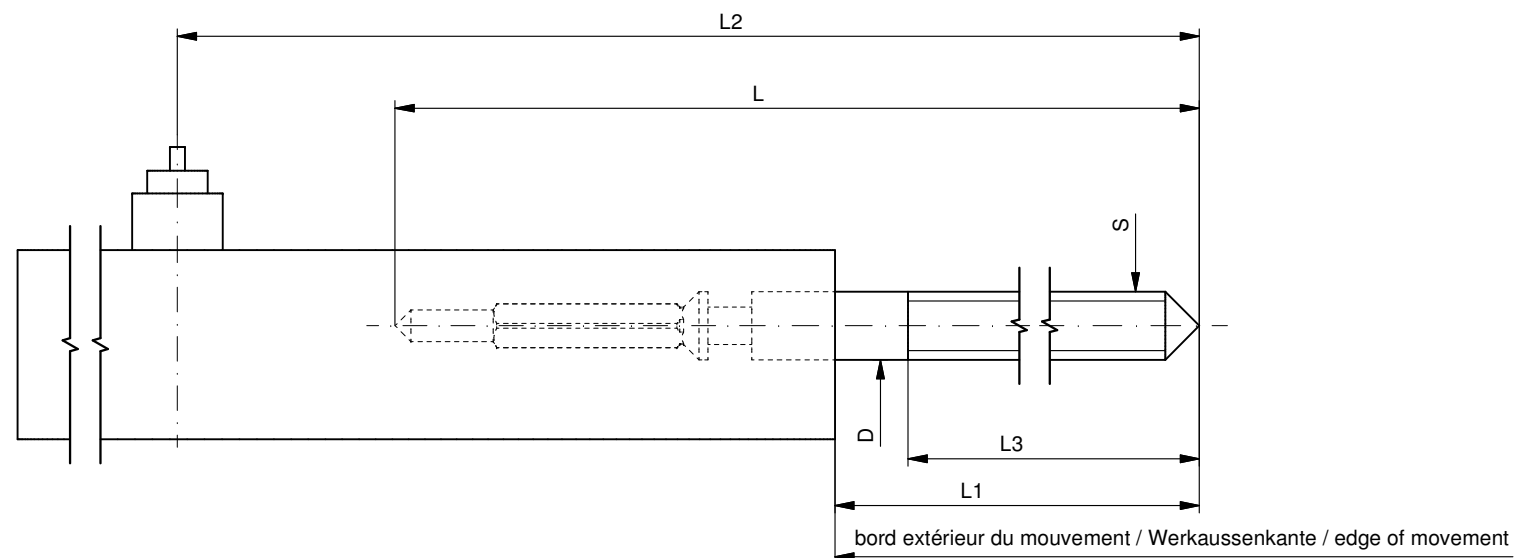

Tige de travail (intégrée dans le mouvement)  
 Arbeitstellwelle (im Werk eingebaut)  
 Working stem (implemented in the movement)

No. d'article Artikelnummer Part number	L	L1	L2	L3	S	D
3000.132.CO	17.00	12.72	19.22	12.70	0.90	0.90

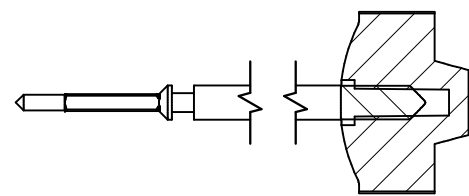

Couleur de la couronne Kronenfarbe Crown color	hellblau bleu clair pale blue
Code	FR 9194

Tige (normale) / Stellwelle (normal) / Stem (normal)

No. d'article Artikelnummer Part number	L	L1	L2	L3	S	D
3000.132	17.00	12.72	19.22	12.70	0.90	0.90
3000.156	25.00	20.72	27.22	14.80	0.90	0.90
3000.139	32.00	27.72	34.22	18.80	0.90	0.90
3000.173	17.00	12.72	19.22	12.60	0.70	0.90

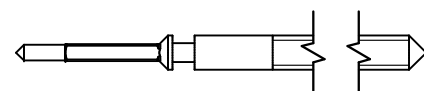

Tige (à arracher)  
 Stellwelle (Ausreissversion)  
 Stem (extractable version)

No. d'article Artikelnummer Part number	L	L1	L2	L3	S	D
3000.143	17.00	12.72	19.22	12.70	0.90	0.90

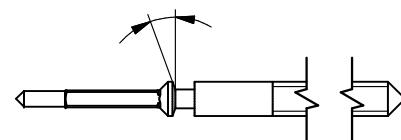

Rallonge de tige / Stellwelle Verlängerung / Stem extension

No. d'article Artikelnummer Part number	L4	L5 (min)	L6	S1	S2	D1
3000.040	12.00	1.90	2.60	0.90	0.90	1.35
3000.046	12.00	1.90	2.60	0.70	0.70	1.00

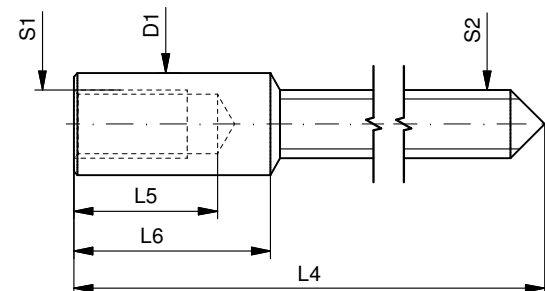

Couronne normale  
 Normale Krone  
 Normal crown

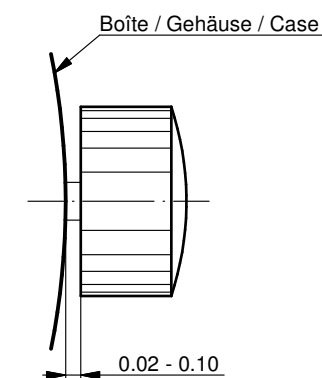

Couronne vissée  
 Geschraubte Krone  
 Screwed crown

Force ⇐ min. Kraft ⇐ min. Force ⇐ min.	10 N
Force ⇐ max. Kraft ⇐ max. Force ⇐ max.	15 N

Tige (dimensions / forces)  
 Stellwelle (Dimensionen / Kräfte)  
 Stem (dimensions / forces)

RONDA 751, 753

Issued	30 Aug 2012	ds5222
Modified	17 Mär 2017 ÄA 34582	mg5224
Released	YES	
Tolerance	---	
Scale	10:1 (A3)	

Sous réserve de modifications  
 Änderungen vorbehalten  
 Modifications reserved

No.	5030.012	02
-----	----------	----

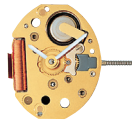

5 1/2<sup>mm</sup>



751/751E



753

**Funktionen**

**Fonctions**

**Functions**

Kaliber Calibre Caliber	Stellwellenpos. Pos. de tige Stem position	Funktionen Fonctions Functions
<b>751/751E</b>	1	Normale Position / Position normale / Running position
	2	Zeiger stellen / Mise à l'heure / Hand setting
<b>753</b>	1	Normale Position / Position normale / Running position
	2	Zeiger stellen, Sekunden-Stopp mit Unterbruch der Motorimpulse Mise à l'heure, stop-seconde avec interruption des impulsions moteur Hand setting, stop-second with interruption of motor pulses

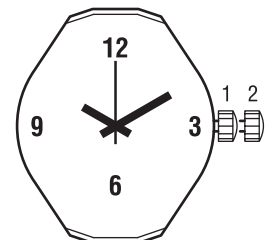

**Batterie**

**Pile**

**Battery**

Kaliber Calibre Caliber	Batterie Pile Battery	Spannung Voltage Tension	Artikelnummer RONDA Numero d'article RONDA Part number RONDA
751/751E/753	379/SR521SW	1.55 V	3600.018.HGF

5 1/2''' 751, 751E, 753

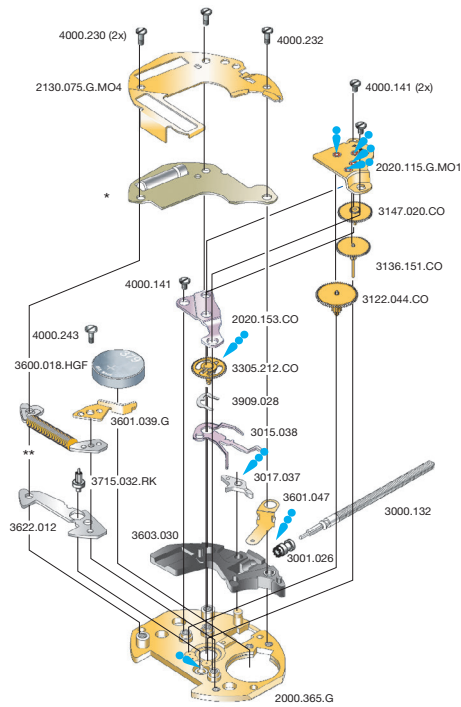

• Düninflüssiges Öl, z.B. Moebius 9014  
 • Fett, z.B. Moebius, Microgloss D5, Jisma 124

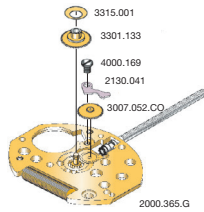

Cal. 753	Werkseite / Côté mouvement / Movement side		
Plan No.	Bestandteile	Fournitures	Spare Parts
2000.365.G	Werkplatte	Platine	Main plate
2020.115.G.M01	Räderwerkbrücke	Pont rouage	Train w. bridge
2020.153.CO	Zentrumbrücke	Pont centre	Centre bridge
2130.075.G.M04	Modul-Abdeckpl.	Couvre module	Module cover pl.
3000.132	Stellwelle	Tige	Stem
3001.026	Kupplungstrieb	Pignon coulant	Sliding pinion
3015.038	Kuppl.-triebhebel	Bascule	Yoke
3017.037	Winkelhebel	Tirette	Setting lever
3122.044.CO	Kleinbodenrad	Roue moyenne	Third wheel
3136.151.CO	Sekundenrad	Roue secondes	Second-wheel
3147.020.CO	Zwischenrad	Roue interméd.	Intermed. wheel
3305.212.CO	Minutenrohr	Chaussée	Cannon pinion
3600.018.HGF	Batterie	Pile	Battery
3601.039.G	Batteriehalter	Bride de pile	Battery clamp
3601.047	Batterie-Kontakt	Bride contact	Battery contact
3603.030	Kunststoffzw.teil	Potence plastique	Setting m. cover
*	Modul	Module	Module
**	Spule	Bobine	Coil
3622.012	Stator	Stator	Stator
3715.032.RK	Rotor	Rotor	Rotor
3909.028	K.-trieb.-feder	Clavette bascule	Pillar spring clip
4000.141	Schraube	Vis	Screw
4000.230	Schraube	Vis	Screw
4000.232	Schraube	Vis	Screw
4000.243	Schraube	Vis	Screw

	751 SWISS MADE	751 SWISS PARTS	753 SWISS MADE	753 SWISS PARTS
<b>* Modul (neu) Module (nouvelle) Module (new)</b>	<b>3612.162</b> grün vert green		<b>3612.152</b> blau bleu blue	<b>3612.163</b> weiss blanc white
<b>** Spule (neu) Bobine (nouvelle) Coil (new)</b>	<b>3621.061.RK</b> gelb jaune yellow			

	751 SWISS MADE	751 SWISS PARTS	753 SWISS MADE	753 SWISS PARTS
<b>* Modul (alt) Module (vieille) Module (old)</b>	<b>3612.063</b> rot rouge red		<b>3612.102</b> gelb jaune yellow	<b>3612.060</b>
<b>** Spule (alt) Bobine (vieille) Coil (old)</b>	<b>3621.014.RK</b> rot rouge red			

Abweichungen / Divergences / Deviations

Cal. 751	Werkseite / Côté mouvement / Movement side		
Plan No.	Bestandteile	Fournitures	Spare Parts
2020.104.CO	Zentrumbrücke	Pont centre	Centre bridge
2020.116.G.M01	Räderwerkbrücke	Pont rouage	Train w. bridge
2130.075.G.M01	Modul-Abdeckpl.	Couvre module	Module cover pl.
3122.045.CO	Kleinbodenrad	Roue moyenne	Third wheel
3305.174.CO	Minutenrohr	Chaussée	Cannon pinion
*	Modul	Module	Module
3622.018	Stator	Stator	Stator
3715.100.RK	Rotor	Rotor	Rotor

Cal. 751E	Werkseite / Côté mouvement / Movement side		
Plan No.	Bestandteile	Fournitures	Spare Parts
3305.198.CO	Minutenrohr	Chaussée	Cannon pinion

Cal. 751, 753	Zifferblattseite / Côté cadran / Dial side		
Plan No.	Bestandteile	Fournitures	Spare Parts
2130.041	Zeigerwerkplatte	Plaque maintien	Maintaining plate
3007.052.CO	Wechselrad	Minuterie	Minute wheel
3301.133	Stundenrad	Canon	Hour wheel
3315.001	Spreizfeder 2 1/2	Clinquant 2 1/2	Washer 2 1/2
4000.169	Schraube	Vis	Screw

Cal. 751E	Zifferblattseite / Côté cadran / Dial side		
Plan No.	Bestandteile	Fournitures	Spare Parts
3301.176	Stundenrad	Canon	Hour wheel



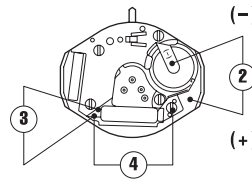
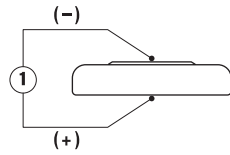

Kaliber Calibre Caliber	Pos. Pos. Pos.	Einheit Unité Unit	Messwerte Valeurs mesurées Measured values	Kontrolle Contrôle Check	Bemerkungen Remarques Remarks
751/751E 753	1	V	1,55	Batterie-Spannung Tension de la pile Battery voltage	Batterie herausnehmen und messen Enlever et mesurer la pile Remove battery for measuring
751/751E 753		$\mu$ A	0,20–0,50 ~ 1,3–2,2	Stromaufnahme Consommation de courant Current consumption	Ohne Batterie, mit externer Speisung Sans pile, avec alimentation externe Without battery, with external power supply
751/751E 753	2	V	$\leq$ 1,30	Funktionskontrolle bei Minimalspannung Contrôle de fonctionnement à tension min. Check with lowest possible voltage	Ohne Batterie, mit externer Speisung Sans pile, avec alimentation externe Without battery, with external power supply
751/751E 753	3	K $\Omega$	1,40–1,60 (2,60–2,90*)	Spulenwiderstand Résistance de la bobine Resistance of the coil	Ohne Batterie Sans pile Without battery
751/751E 753	4	K $\Omega$	$\infty$	Spulenisolation Isolation de la bobine Coil insulation	Ohne Batterie Sans pile Without battery
751/751E 753		Sek./Monat sec./mois sec./month	- 10/+ 20	Induktivsonde 60 Sek. Senseur inductif 60 sec. Inductive sensor 60 sec.	Mit Batterie Avec pile With battery

Werte (\*) gelten für rote Spule (s. Seite 2)

Valeurs (\*) sont valid pour bobine rouge (v. page 2)

Values (\*) are valid for red coil (see pages 2)

## Einschalen / Werkzeuge

## Emboîtage / outils

## Casing / tools

Nr. H 75x.1A



Nr. H 75x.1T



75x.1A	SWISS MADE & SWISS PARTS
Schraube Vis Screw	

### Zeigersetzen

Maximale Aufpresskraft:

- Stunden und Minutenzeiger: max. 40N
- Sekundenzeiger: max. 30N

Beim Zeigersetzen muss das Werk abgestützt werden.

### Poser les aiguilles

Force de chassage maximale:

- Aiguilles des heure et des minutes: max. 40N
- Aiguille des secondes: max. 30N

Lors de la pose d'aiguilles, le mouvement doit être soutenu.

### Hand setting

Maximal force:

- Hour and minute hands: max. 40N
- Second hand: max. 30N

The movement needs to be supported for hand setting.

### Stellwelle entfernen

Beim Entfernen der Stellwelle muss sich die Stellwelle in Position 1 (gedrückt) befinden, bevor auf den Winkelhebel gedrückt wird.

### Enlever la tige

En enlevant la tige, la tige doit se trouver en position 1 (poussée), avant de pousser sur la tirette.

### Stem removal

For removal of the stem, the stem must be pushed into position 1 (pressed in) prior to apply pressure to the setting lever.