

RONDA startech 4000

Multifunktionen mit Grossdatum,
Alarm, zweiter Zeitzone

Kaliber 4002.B – 12½'''



Produktespezifikationen

Analog-Quarzuhrwerk

Linie

startech

Kaliber

4002.B

Werkgrösse

12½'''

Version Swiss Made

5 Steine / vergoldet

Standard Batterie Laufzeit

60 Monate

Zeigerwerkhöhe

0

Spezielle Merkmale

- Reparierbares Metalluhrwerk
- Sehr lange Batterielaufzeit
- Energieeinsparungs-Funktion bei gezogener Stellwelle:
Reduktion des Stromverbrauchs um ca. 70%

Funktionen

- Grossdatum
- 2 Zeiger

Technische Spezifikationen

Gesamtabmessung	28.60 mm
Werksitz	28.00 mm
Werkhöhe	4.40 mm
Höhe über Standard Batterie	4.40 mm
Höhe der Werkauflage	0.60 mm
Stellwellenhöhe	1.90 mm
Stellwellen-Weg	0.90 mm
Kraft für das Eindrücken der Stellwelle mit geschraubter Krone	10 / 15 N
Stellwelle Gewinde	0.90 mm
Standard Batterie	395
Standard Batterie Laufzeit	60 Monate
Batterie-Spannung	1.5 V
Stromverbrauch – typisch	1.19 µA (Kalender nicht im Eingriff)
Stromverbrauch – max.	1.65 µA (Kalender nicht im Eingriff)
Drehmoment Minute – typisch	300 µNm
Betriebstemperatur	0 - 50 °C
Momentaner Gang	-10/ +20 Sek/Monat
Magnetfeldabschirmung	18.8 Oe
Schockresistenz	NIHS 91-10



Aiguillage No.0
Zeigerwerkhöhe Nr.0
Hand height Nr.0

Important: l'aiguillage peut varier selon le modèle
Wichtig: die Zeigerwerkhöhe kann bei verschiedenen Modellen unterschiedlich sein
Important: the hand height can vary between different models

Sécurité entre l'aiguille des minutes et le verre:
Sicherheit zwischen Minutenzeiger und Glas: 0.30mm
Security between minute hand and glass:

Le cadran doit être tenu par la boîte
Das Zifferblatt muss durch die Schale gehalten werden
The dial must be hold by the case

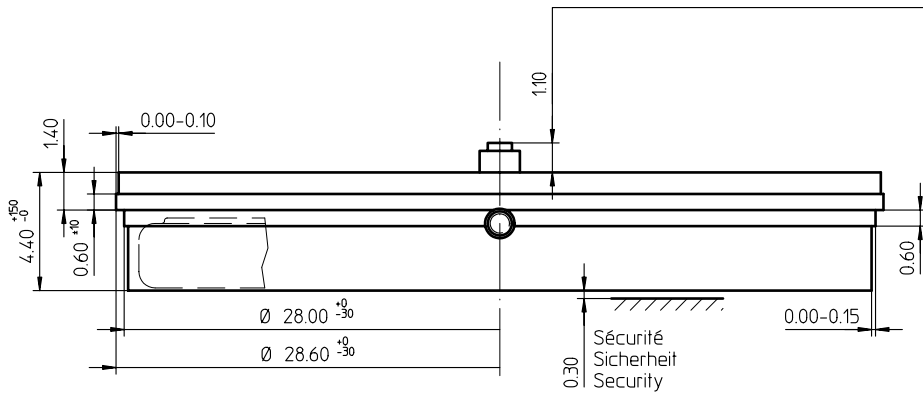

Côté fond de boîte
Seite Gehäuseboden
Case back side

Pile Batterie (395) Ø 9.50 x 2.60mm
Battery

Position pour extraire la tige
Position zum Entfernen der Stellwelle
Position to remove the stem

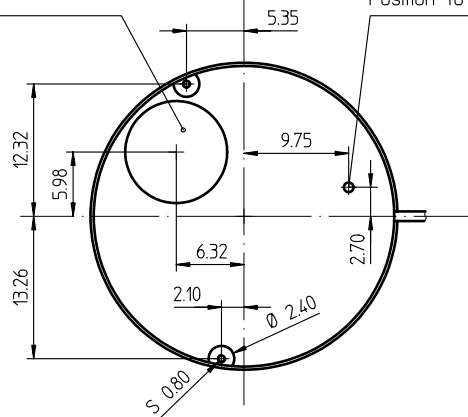

Stellwelle
Tige
Stem

Chemin:
Weg: 0.90
Way:

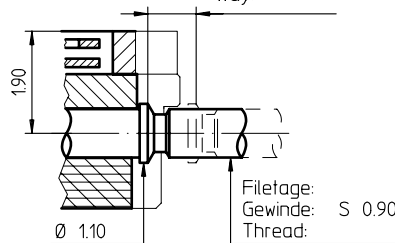

Vis
Schraube Nr. 4000.310
Screw

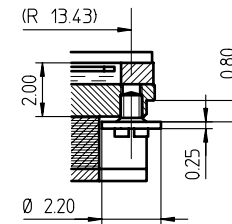

Vis
Schraube Nr. 4000.195
Screw

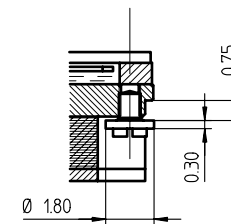

Vis
Schraube Nr. 4000.194
Screw

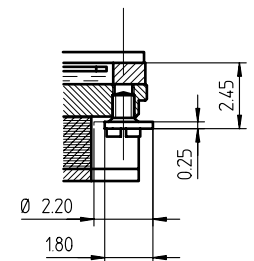

Cage
Uhrwerkgestell
Frame

12½"

RONDA

4002.B

Issued	01 Nov 2004	mk
Modified	20.Juni 2007 ÅA 2180	mk
Released	YES	
Tolerance	+/- 20 µm	
Scale	10 : 1 (5 : 1) (A3H)	

Sous réserve de modifications
Aenderungen vorbehalten
Modifications reserved

No. 5000.346 01

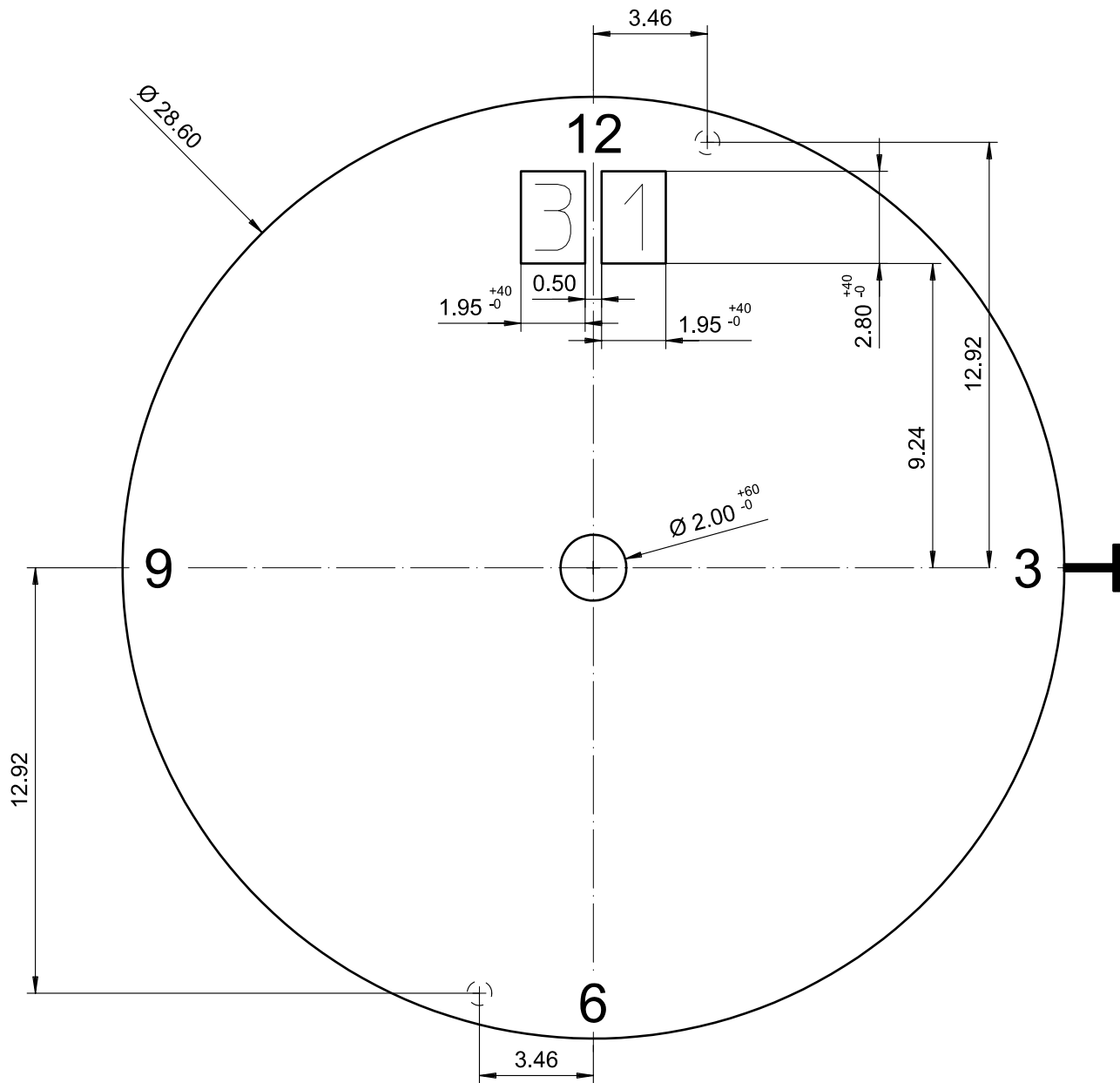

Tige	Date
Stellw.	Datum
Stem	Date
3H	12H
□	

Epaisseur du cadran selon hauteur de l'aiguillage
 Zifferblattdicke gemäss Zeigerwerkhöhen
 Dial thickness according to hand fitting heights

Cadran
 Zifferblatt
 Dial

12½"

Issued	13 Dez 2006	cw
Modified	15.Dez.2006 ÄA ----	cm
Released	YES	
Tolerance	+/- 20 µm	
Scale	5 : 1 (A4V)	

RONDA

4002.B, 4003.B

Sous réserve de modifications
 Aenderungen vorbehalten
 Modifications reserved

No. 5010.701 01

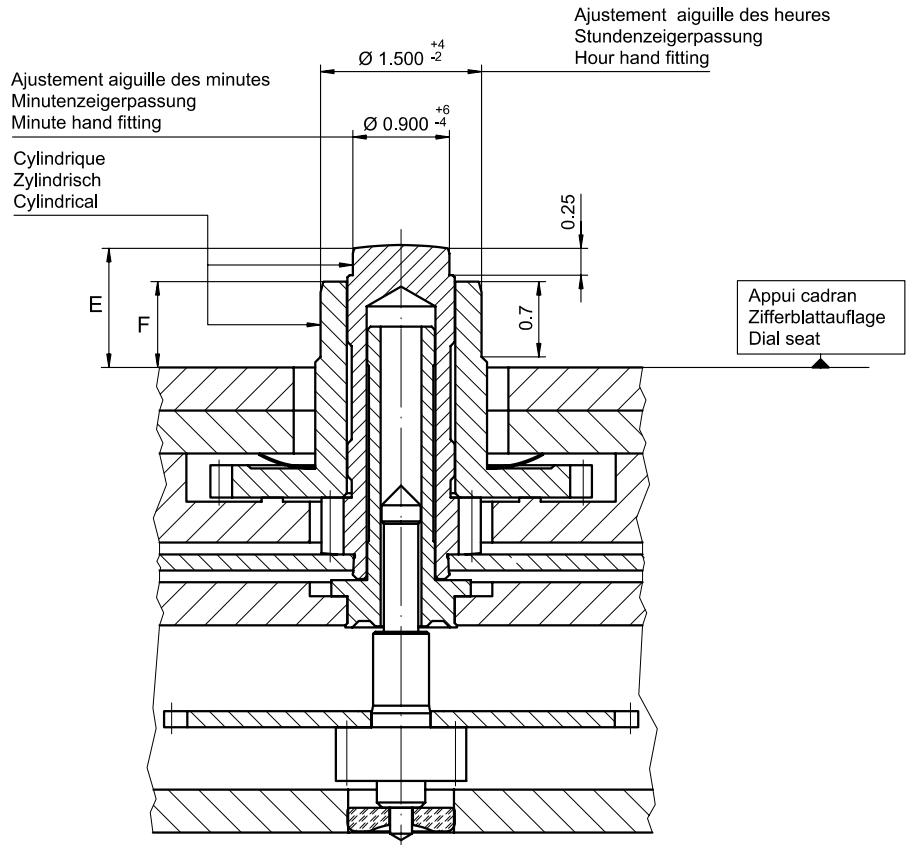

Heures / minutes
Stunden / Minuten
Hours / minutes

	Aig. des minutes Minutenzeiger Minute hand	Aig. des heures Stundenzeiger Hour hand	Lors de la pose d'aiguilles, le mouvement doit être soutenu. Beim Zeigersetzen muss das Werk abgestützt werden. The movement needs to be supported for hand setting.
mg max.	30	30	Masse / Masse / Weight *
µNm max.	0.80	0.80	Balourd / Unwucht / Unbalance *
gmm ² max.	-	-	Inertie / Massenträgheit / Inertia *
N max.	40	40	Force de chassage / Aufpresskraft / Force

Aiguillages Zeigerwerkhöhe Hand fitting height		
Dépassement Höhe über Zifferblattaufgabe Height over dial seat		
	Chausée Minutenrohr Cannon-pinion	Roue des heures Stundenrad Hour wheel
No	E	F
0	1.10	0.80
-		

Aiguillages Zeigerwerkhöhe Hand fitting height			
Peinture comprise / inkl. Farbe / Paint included			
Epaisseur maximum du cadran Maximale Zifferblattdicke Maximum dial thickness			
No	Sous l'aiguille des minutes Unter Minutenzeiger Under minute hand	Sous l'aiguille des heures Unter Stundenzeiger Under hour hand	Epaisseur des aiguilles Zeigerdicke Hands thickness
0	0.70	0.40	0.15
-			

Sous réserve de toutes modifications Änderungen vorbehalten All modifications reserved

Aiguillages Zeigerwerkhöhen Hand fitting heights	12½"	Issued	01 Nov 2004	mk
	Modified	02.08.2010 ÅA 2120	dh	
	Released	Yes		
	Tolerance	µm		
	Scale	20 : 1 (A3H)		
RONDA 4002.B		Sous réserve de modifications Änderungen vorbehalten Modifications reserved		
		No.	3316.091	01

* En cas de données différentes, veuillez contacter le service après-vente

* Bei abweichenden Werten, bitte technischen Kundendienst anfragen

* In case of different values, please contact the customer service

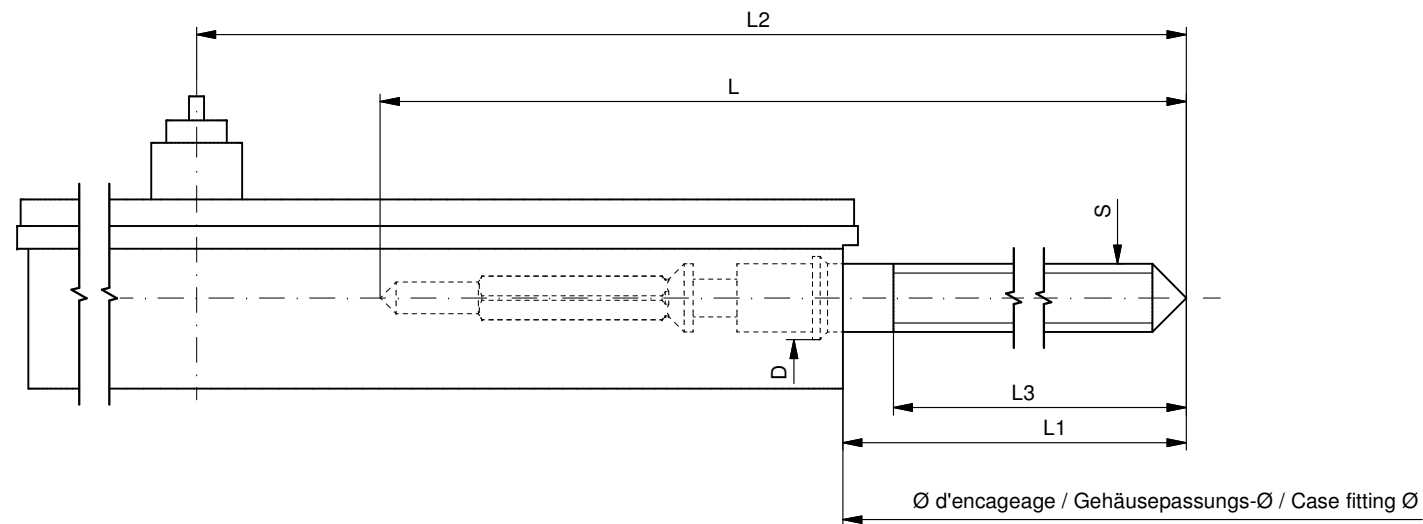

Tige de travail (intégrée dans le mouvement)
 Arbeitstellwelle (im Werk eingebaut)
 Working stem (implemented in the movement)

No. d'article Artikelnummer Part number	L	L1	L2	L3	S	D
3000.177.CO	20.00	10.23	24.23	10.15	0.90	1.10

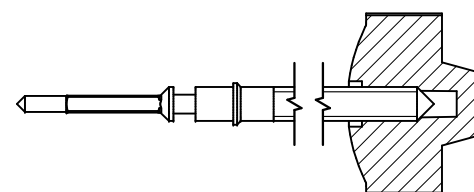

Couleur de la couronne Kronenfarbe Crown color	bleu foncé dunkelblau dark blue
Code	UN 5002

Tige (normale) / Stellwelle (normal) / Stem (normal)

No. d'article Artikelnummer Part number	L	L1	L2	L3	S	D
3000.177	20.00	10.23	24.23	10.15	0.90	1.10
3000.191	32.00	22.23	36.23	22.15	0.90	1.10

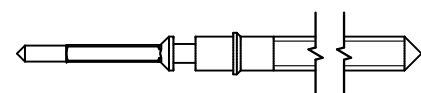

Couronne normale
 Normale Krone
 Normal crown

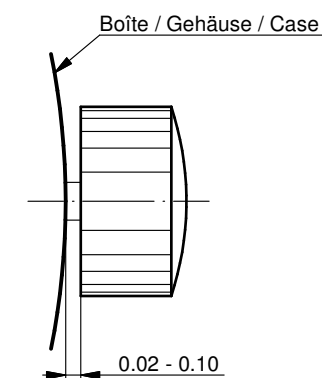

Couronne vissée
 Geschraubte Krone
 Screwed crown

Force ⇄ min. Kraft ⇄ min. Force ⇄ min.	10 N
Force ⇄ max. Kraft ⇄ max. Force ⇄ max.	15 N

Rallonge de tige / Stellwelle Verlängerung / Stem extension

No. d'article Artikelnummer Part number	L4	L5 (min)	L6	S1	S2	D1
3000.040	12.00	1.90	2.60	0.90	0.90	1.35

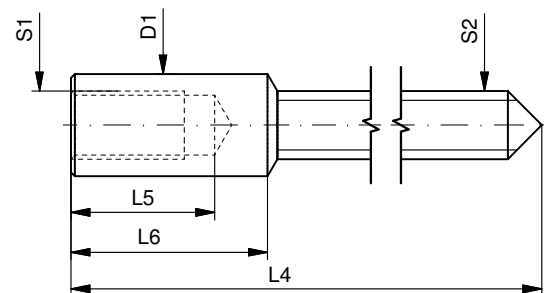

Tige (dimensions / forces)
 Stellwelle (Dimensionen / Kräfte)
 Stem (dimensions / forces)

RONDA

4002.B, 4003.B, 4120.B,
 4210.B, 4220.B

Issued	05 Sep 2012	ds5222
Modified	17 Mär 2017 ÄA 34582	mg5224
Released	YES	
Tolerance	---	
Scale	10:1 (A3)	

Sous réserve de modifications
 Änderungen vorbehalten
 Modifications reserved

No.	5030.018	02
-----	----------	----



Werkhalter
Stellwelle entfernen
H5XXX.1T



Werkhalter
Zeiger setzen
H5XXX.1A

Zifferblatt- und Zeigersetzen

- Krone in Position II
- Krone drehen bis das Datum 02 erscheint
- Krone in Position III
- Stundenzeiger vorwärts drehen bis das Datum auf 03 wechselt
- Arbeitszeiger entfernen
- Zifferblatt setzen
- Alle Zeiger in Richtung 12 Uhr setzen
- Uhrzeit einstellen
- Krone in Position II
- Datum einstellen
- Krone in Position I

Datumsschaltdauer

Einer- und Zehnerscheibe

~2h

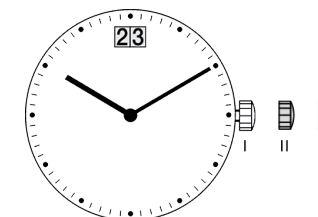

Allgemeine Hinweise

Das Entfernen der Stellwelle kann ausschliesslich in Pos. I erfolgen.

Zum Setzen der Zeiger ist die Verwendung von Abstützschrauben unerlässlich.

Zulässige Zeigersetzkräfte:

Std.- / Min.-Zeiger: <40N

Während der Schnellkorrektur des Datums (Stellwelle in Position II) darf eine Kalenderschaltgeschwindigkeit von 5 d/s nicht überschritten werden.

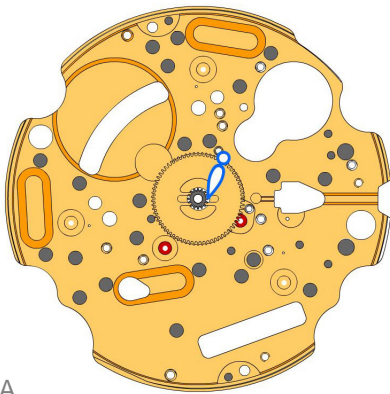

A

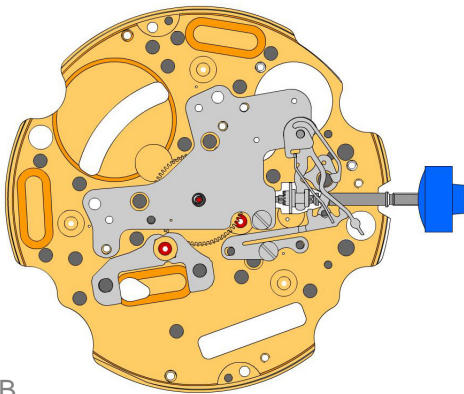

B

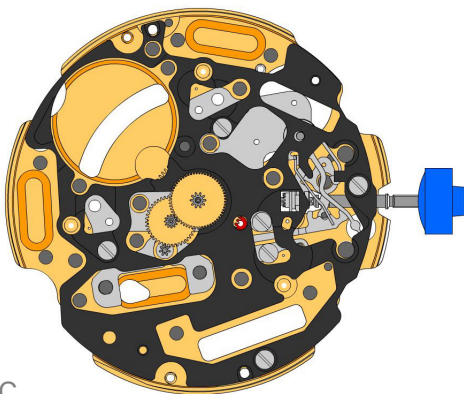

C

2000.577.G 1.		Werkplatte
3305.315.CO 2.		Minutenrohr mit Mitnehmer (Aig.0, geschlossen)
2030.017.CO 3.		Zentrumbrücke Zentrumbrücke gehalten durch 1 Schraube 4000.250. Die Teile 2030.017.CO, 3004.223 und 3500.059 sind zusammen auszutauschen.
4000.250 4.		Schraube
3001.055.FI 5.		Kupplungstrieb
3000.177.CO 6.		Stellwelle
3017.049 7.		Winkelhebel
3905.049 8.		Winkelhebelraste (3 Positionen) Winkelhebelraste gehalten durch 1 Schraube 4000.250.
4000.250 9.		Schraube
3015.081 10.		Wippe (3 Positionen) Die Teile 3015.081 und 3905.067 sind zusammen auszutauschen.
3905.067 11.		Wippenfeder Den Federarm spannen. Die Teile 3015.081 und 3905.067 sind zusammen auszutauschen.
3622.039 12.		Stator (Zähler 6h, 9h, Chrono)
3603.079 13.		Kunststoffhalterung Kunststoffhalterung gehalten durch 4 Schrauben 4000.250.
4000.250 14.		Schraube
3715.094.RK 15.		Rotor
3147.047.CO 16.		Zwischenrad (Chrono)
3136.170.CO 17.		Zentrumsekundenrad (kurz)

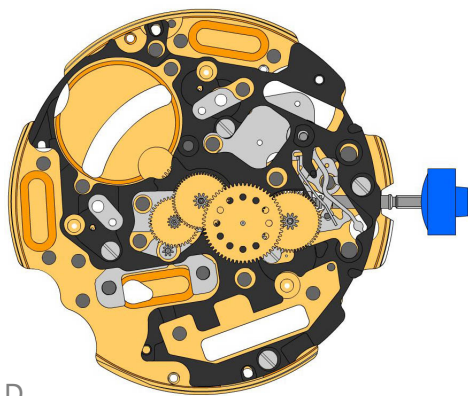

D

 3136.148.CO
18.  Sekundenrad (kurz)

 3122.056.CO
19.  Kleinbodenrad

 2020.164.G
20.  Räderwerkbrücke
Räderwerkbrücke gehalten durch 3 Schrauben 4000.250.

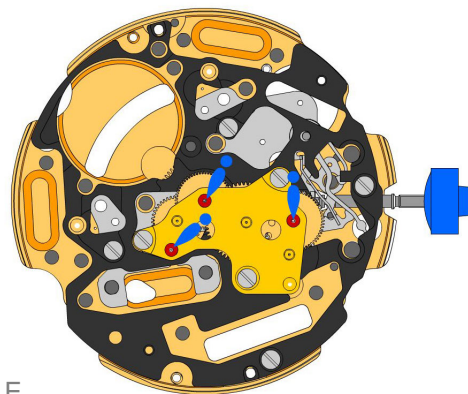
 4000.250
21.  Schraube

E

 3621.079.RK
22.  Spule (Zentrum)
Achtung: Spule nur am grauen Spulenkern halten. Spule gehalten durch 1 Schraube 4000.250

 4000.250
23.  Schraube

 3603.034
24.  Isolation für Batterie

 3503.071
25.  Lagerrohr

 3601.118
26.  Kontaktbügel
Kontaktbügel gehalten durch 1 Schraube 4000.250.

 4000.250
27.  Schraube

 3503.059
28.  Lagerrohr

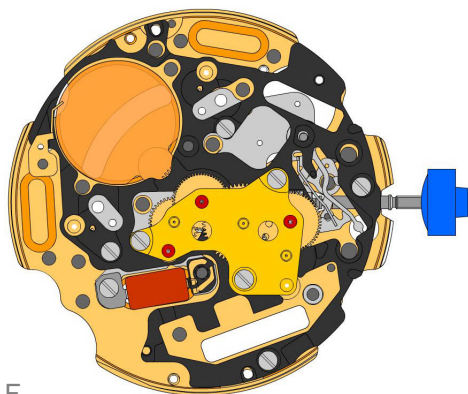
 3503.068
29.  Lagerrohr

F

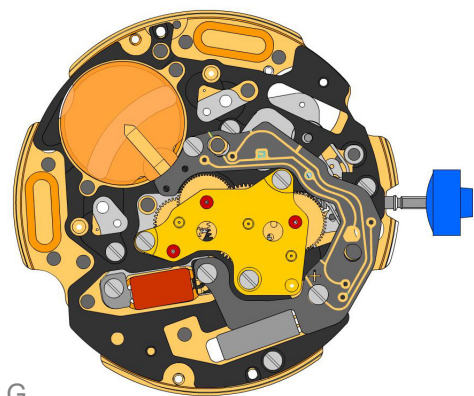

G

 3612.147.4003
30.

Elektronikmodul

Elektronikmodul gehalten durch 3 Schrauben 4000.248. Elektronische Messungen können nun vorgenommen werden.

 4000.248
31.

Schraube

 3603.069
32.

Isolation für Schaltung

 3601.107.G
33.

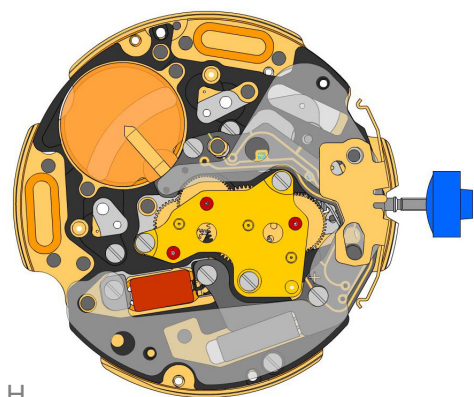
Drückerkontaktfeder

H

 2130.176.G.M01.4002B
34.

Deckplatte für Elektronikmodul

Deckplatte für Elektronikmodul gehalten durch 3 Schrauben 4000.250.

 3600.010.HGF
35.

Batterie 395

 3601.109.G
36.

Bügel +

Bügel gehalten durch 1 Schraube 4000.250.

 4000.250
37.

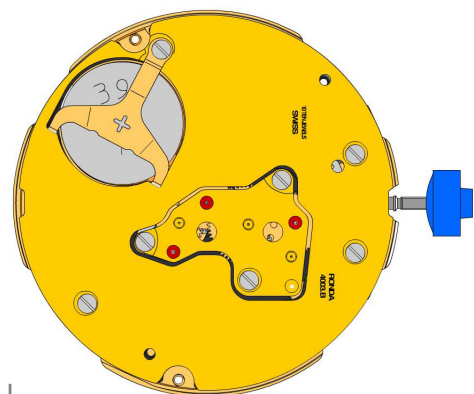
Schraube



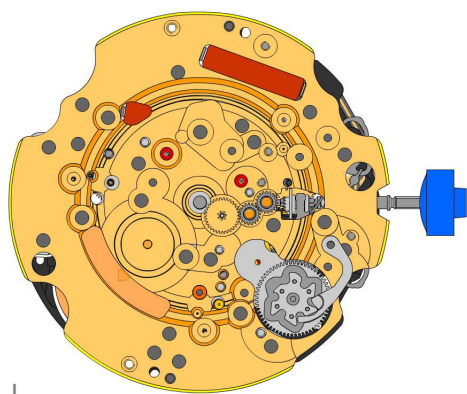



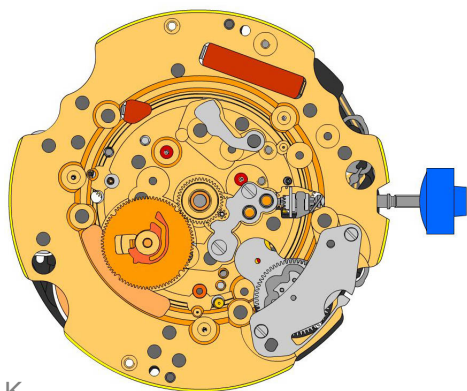







I



J



K

2000.577.G 38.		Werkplatte
3004.164 39.		Zeigerstellrad
3004.164 40.		Zeigerstellrad
3007.054.CO 41.		Wechselrad
2130.143 42.		Wechselradbrücke Wechselradbrücke gehalten durch 2 Schrauben 4000.305.
4000.305 43.		Schraube
3004.223 44.		Zehnermitnehmerrad Die Teile 2030.017.CO, 3004.223 und 3500.059 sind zusammen auszutauschen. Kurzer Zahn des Zehnermitnehmerrades in Richtung Werkszentrum positionieren.
3500.059 45.		Zehneraste Die Teile 2030.017.CO, 3004.223 und 3500.059 sind zusammen auszutauschen.
2130.142 46.		Halteplatte für Zehneraste Halteplatte für Zehneraste gehalten durch 2 Schrauben 4000.306. Den Federarm spannen.
4010.306 47.		Schraube
3301.285 48.		Stundenrad (Aig.0)
3315.016 49.		Frikionsfeder
3004.224.CO 50.		Datumanzeiger-Mitnehmerrad
3500.049 51.		Datumraste

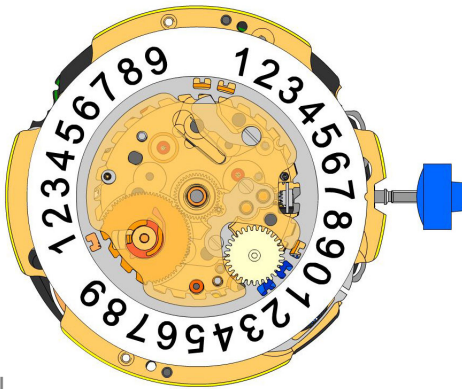

L

3504.214.AD.1.A 52.		Einer Anzeiger (Standard) Einbuchtung im Disc bei 3 Uhr.
3147.054 53.		Zehnerzwischenrad
2130.141 54.		Halteplatte für Datumanzeige Halteplatte für Datumanzeige gehalten durch 2 Schrauben 4000.250.
3905.070 55.		Feder für Datumraste Feder für Datumraste in die Öffnung einfügen.

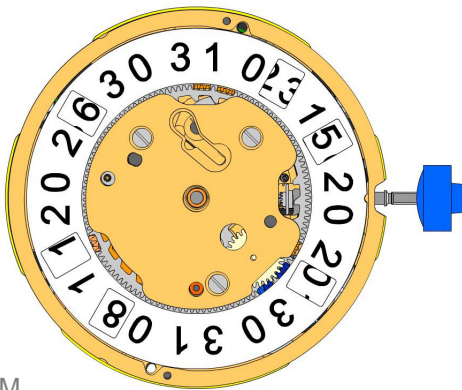

M

3504.215.AD.1.A 56.		Zehner Anzeiger (Standard) Einbuchtung im Disc bei 3 Uhr.
2130.140.G 57.		Halteplatte für Datum-Mechanismus Halteplatte für Datum-Mechanismus gehalten durch 2 Schrauben 4000.250.
4000.250 58.		Schraube
3506.072.G 59.		Träger für Zifferblatt
8200 60.		Moebius 8200
124 61.		Jismaa 124
9014 62.		Moebius 9014
9020 63.		Moebius 9020

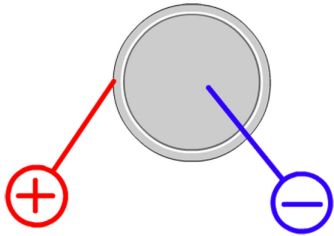

Batterie	395
Spannung	1.55 V

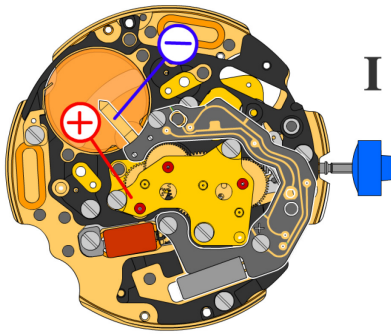

*Stellwelle in Position I, Kalender nicht im Eingriff,
60 s Messintervall für Gang und Verbrauch:*

Typischer Verbrauch	1.19 μA
Maximaler Verbrauch	1.65 μA
Gang	-10s/M. .. +20s/M.
Untere Funktionsspannungsgrenze	1.20 V

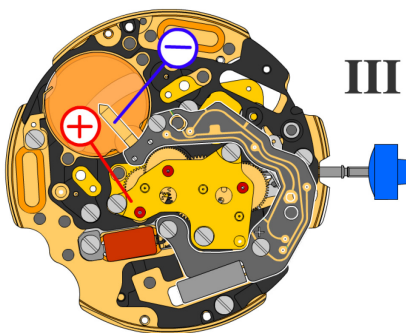

Stellwelle in Position III, 60 s Messintervall:

Typischer Verbrauch	0.10 μA
Maximaler Verbrauch	0.30 μA

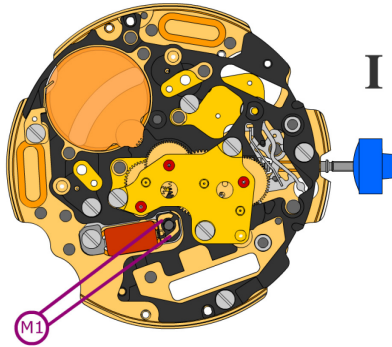

Spulenwiderstand M1

2.20 k Ω .. 2.40 k Ω

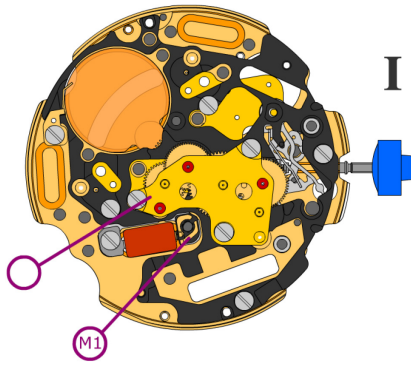

Spulenisolation M1

∞ k Ω

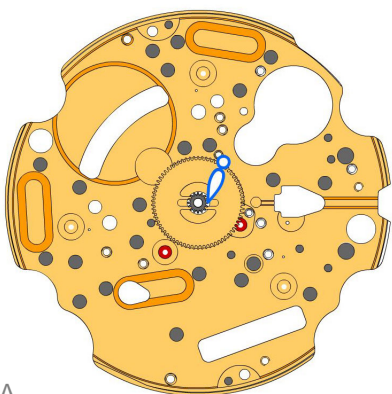



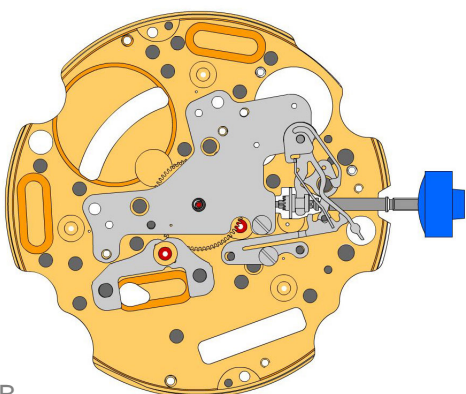



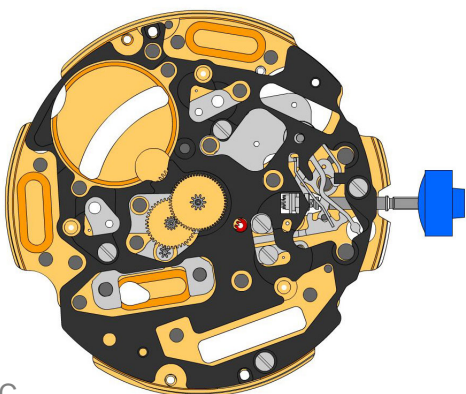









A



B



C

2000.577.G 1.		Werkplatte
3305.315.CO 2.		Minutenrohr mit Mitnehmer (Aig.0, geschlossen)
2030.037.CO 3.		Zentrumbrücke Zentrumbrücke gehalten durch 1 Schraube 4000.250.
4000.250 4.		Schraube
3001.055.FI 5.		Kupplungstrieb
3000.177.CO 6.		Stellwelle
3017.049 7.		Winkelhebel
3905.049 8.		Winkelhebelraste (3 Positionen) Winkelhebelraste gehalten durch 1 Schraube 4000.250.
4000.250 9.		Schraube
3015.081 10.		Wippe (3 Positionen)
3905.067 11.		Wippenfeder Den Federarm spannen.
3622.039 12.		Stator (Zähler 6h, 9h, Chrono)
3603.079 13.		Kunststoffhalterung Kunststoffhalterung gehalten durch 4 Schrauben 4000.250.
4000.250 14.		Schraube
3715.094.RK 15.		Rotor
3147.047.CO 16.		Zwischenrad (Chrono)
3136.170.CO 17.		Zentrumsekundenrad (kurz)

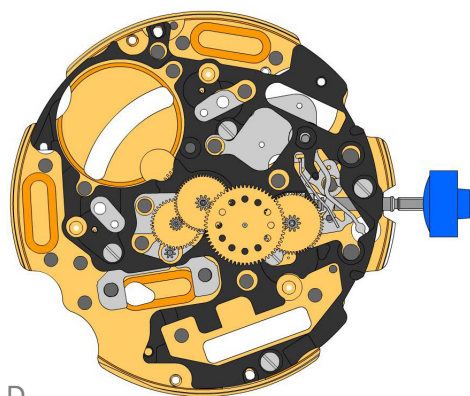

D

 3136.148.CO
 18.  Sekundenrad (kurz)

 3122.056.CO
 19.  Kleinbodenrad

 2020.164.G
 20.  Räderwerkbrücke
 Räderwerkbrücke gehalten durch 3 Schrauben 4000.250.

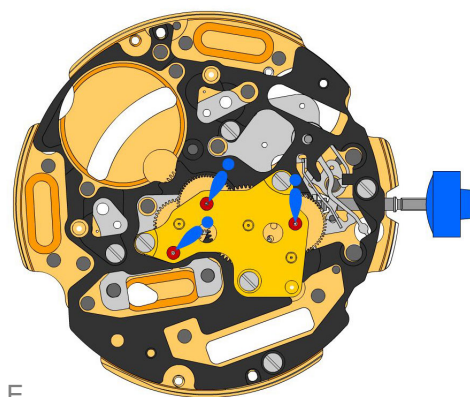
 4000.250
 21.  Schraube



E

 3621.079.RK
 22.  Spule (Zentrum)
 Achtung: Spule nur am grauen Spulenkern halten. Spule gehalten durch 1 Schraube 4000.250.

 4000.250
 23.  Schraube

 3603.034
 24.  Isolation für Batterie

 3503.071
 25.  Lagerrohr

 3601.118
 26.  Kontaktbügel
 Kontaktbügel gehalten durch 1 Schraube 4000.250.

 4000.250
 27.  Schraube

 3503.059
 28.  Lagerrohr

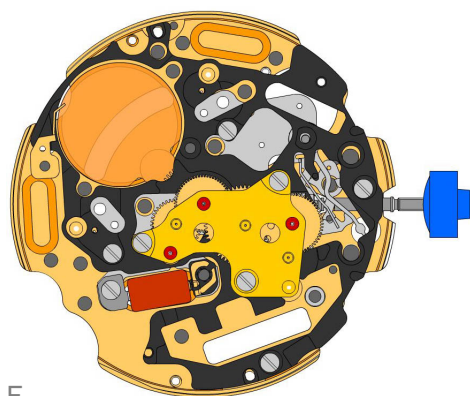
 3503.068
 29.  Lagerrohr

F

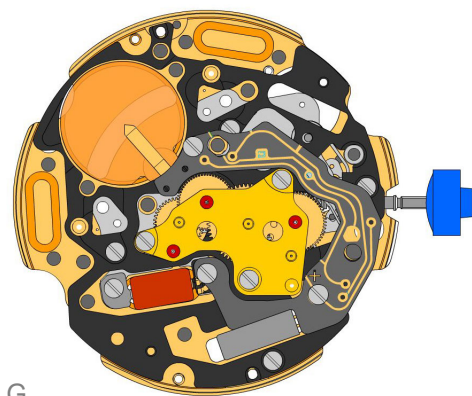

G

 3612.147.4003
30.

Elektronikmodul

Elektronikmodul gehalten durch 3 Schrauben 4000.248. Elektronische Messungen können nun vorgenommen werden.

 4000.248
31.

Schraube

 3603.069
32.

Isolation für Schaltung

 3601.107.G
33.

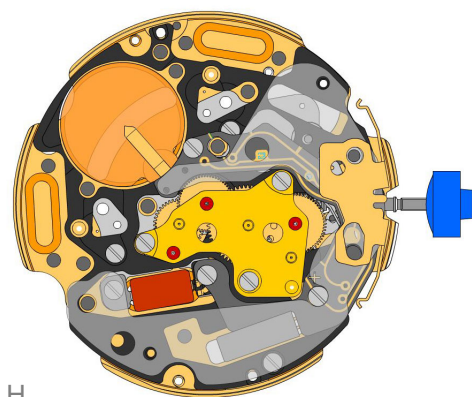
Drückerkontaktfeder

H

 2130.176.G.M01.4002B
34.

Deckplatte für Elektronikmodul

Deckplatte für Elektronikmodul gehalten durch 3 Schrauben 4000.250.

 3600.010.HGF
35.

Batterie 395

 3601.109.G
36.

Bügel +

Bügel gehalten durch 1 Schraube 4000.250.

 4000.250
37.

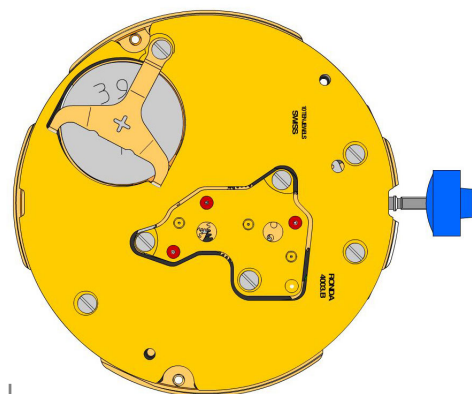
Schraube



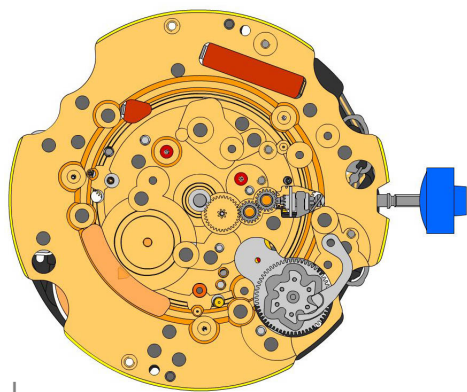



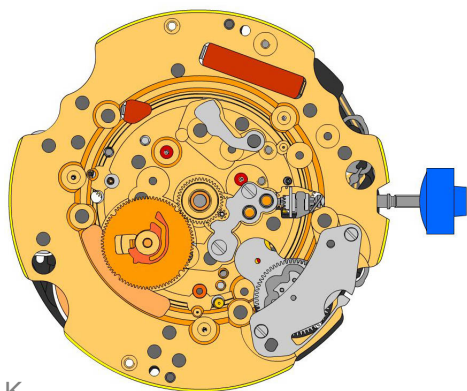

I



J



K

2000.577.G 38.		Werkplatte
3004.164 39.		Zeigerstellrad
3004.164 40.		Zeigerstellrad
3007.054.CO 41.		Wechselrad
2130.143 42.		Wechselradbrücke Wechselradbrücke gehalten durch 2 Schrauben 4000.305.
4000.305 43.		Schraube
3004.227 44.		Zehnermitnehmerrad Kurzer Zahn des Zehnermitnehmerrades in Richtung Werkszentrum positionieren.
3500.075 45.		Zehnerraste
2130.142 46.		Halteplatte für Zehnerraste Halteplatte für Zehnerraste gehalten durch 2 Schrauben 4000.306. Den Federarm spannen.
4010.306 47.		Schraube
3301.285 48.		Stundenrad (Aig.0)
3315.016 49.		Frikionsfeder
3004.224.CO 50.		Datumanzeiger-Mitnehmerrad
3500.049 51.		Datumraste

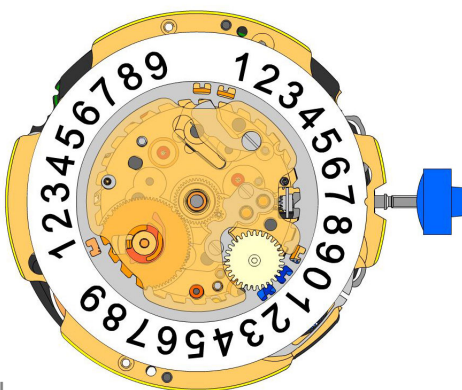





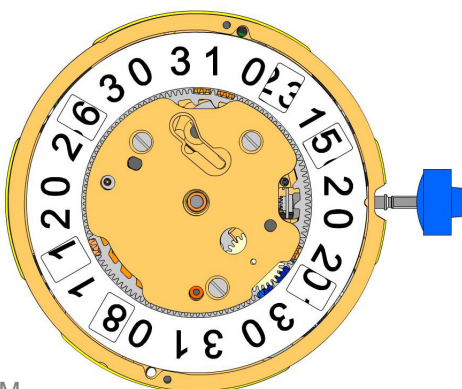



L

3504.214.AD.1.A 52.		Einer Anzeiger (Standard) Einbuchtung im Disc bei 3 Uhr.
3147.054 53.		Zehnerzwischenrad
2130.141 54.		Halteplatte für Datumanzeige Halteplatte für Datumanzeige gehalten durch 2 Schrauben 4000.250.
3905.070 55.		Feder für Datumraste Feder für Datumsraste in die Öffnung einfügen.



M

3504.215.AD.1.A 56.		Zehner Anzeiger (Standard) Einbuchtung im Disc bei 3 Uhr.
2130.140.G 57.		Halteplatte für Datum-Mechanismus Halteplatte für Datum-Mechanismus gehalten durch 2 Schrauben 4000.250.
4000.250 58.		Schraube
3506.072.G 59.		Träger für Zifferblatt
8200 60.		Moebius 8200
124 61.		Jismaa 124
9014 62.		Moebius 9014
9020 63.		Moebius 9020

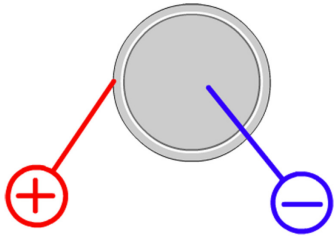

Batterie	395
Spannung	1.55 V

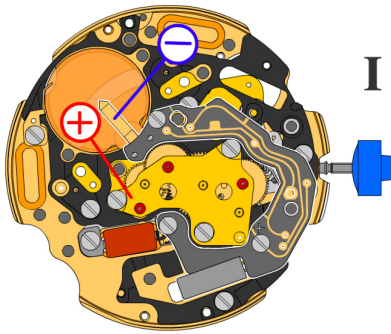

*Stellwelle in Position I, Kalender nicht im Eingriff,
60 s Messintervall für Gang und Verbrauch:*

Typischer Verbrauch	1.19 μA
Maximaler Verbrauch	1.65 μA
Gang	-10s/M. .. +20s/M.
Untere Funktionsspannungsgrenze	1.20 V

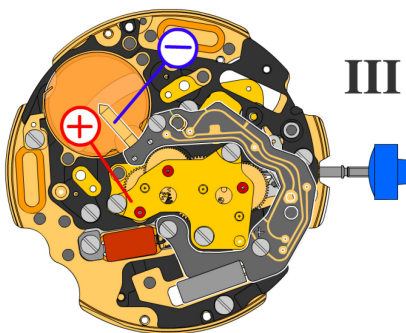

Stellwelle in Position III, 60 s Messintervall:

Typischer Verbrauch	0.10 μA
Maximaler Verbrauch	0.30 μA

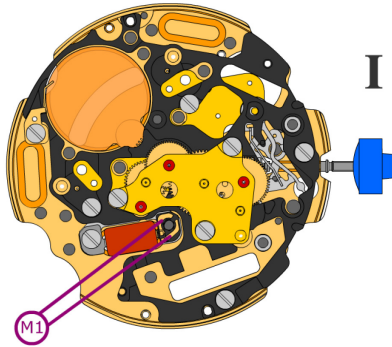

Spulenwiderstand M1

2.20 k Ω .. 2.40 k Ω

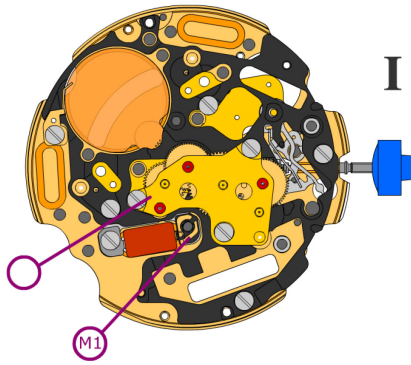

Spulenisolation M1

∞ k Ω