

RONDA slimtech 1000

Extra small and slim movements
for exclusive styles

Caliber 1032 – 3³/₄ x 6'''

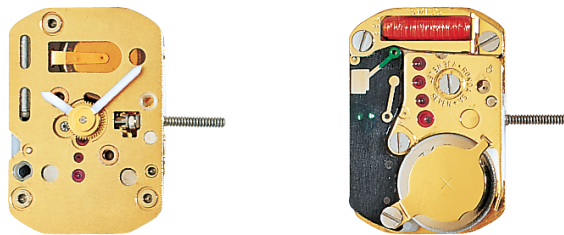

Product Specifications

Analog quartz movement

Line slimtech

Caliber 1032

Size 3³/₄ x 6'''

Version Swiss Made 7 Jewels / gold plated
Swiss Parts 7 Jewels / nickel plated

Standard battery life 60 months

Hand fitting height 1

Features

- Do not pull stem during storage
- Repairable metal watch movement
- Very long battery life

Functions

– 2 hands

Technical Specifications

Diameter Total	9.00 mm
Case fitting	9.00 mm
Movement height	1.95 mm
Height over standard battery	2.10 mm
Movement rest	0.20 mm
Height over stem	0.62 mm
Length of stem travel	0.30 mm
Force to push the stem for screwed crown	N
Stem thread	0.70 mm
Standard battery	317
Standard battery life	60 months
Battery voltage	1.5 V
Current consumption – typical	0.25 µA
Current consumption – maximum	0.3 µA
Useful torque minute – typical	21 µNm
Operating temperature	0 - 50 °C
Instantaneous rate	-10/ +20 sec/month
Resistance to magnetic fields	18.8 Oe
Resistance against shock	NIHS 91-10



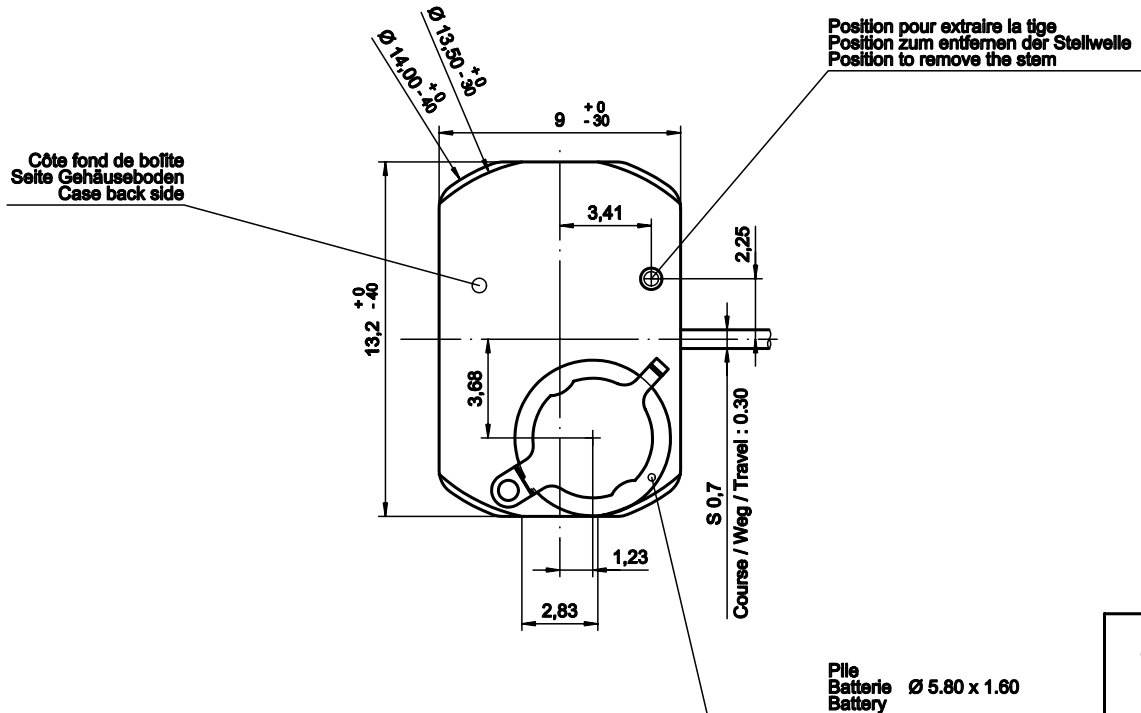
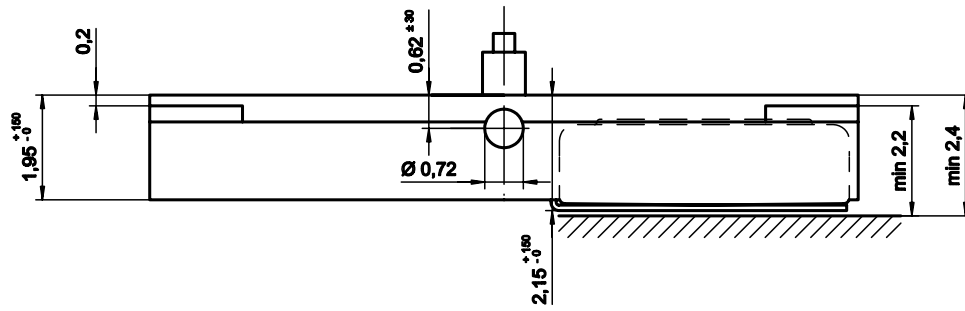

Sécurité entre aiguille minute et verre : min 0.30 mm
 Sicherheit zwischen Minutenzeiger und Glas : min 0.30 mm
 Security between minute hand and glass : min 0.30 mm

Le cadran doit être maintenu en hauteur par la boîte.
 Das Zifferblatt muss in der Höhe vom Gehäuse festgehalten werden.
 The dial must be held in the height by the case.

Cage Uhrwerkgestell Frame	3 3/4 x 6 mm	Issued	04 Feb 1988	ks
		Modified	11. Dez. 2006	cm
		Released	AA —	
		Tolerance	+/- 20 µm	
		Scale	10 : 1 (5 : 1) (A3H)	
RONDA	1032	Sous réserve de modifications Aenderungen vorbehalten Modifications reserved		
		No.	5000.256	14

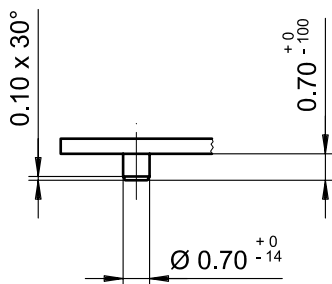
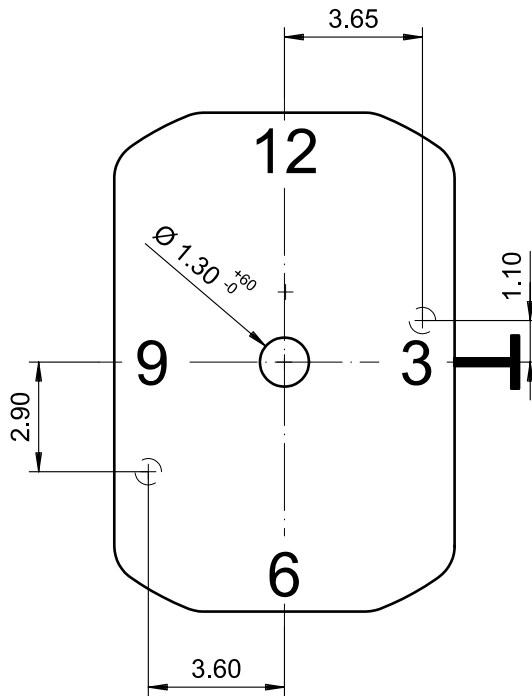

Epaisseur du cadran selon hauteur de l'aiguillage
 Zifferblattdicke gemäss Zeigerwerkhöhen
 Dial thickness according to hand fitting heights

Tige
Stellw.
Stem
3H

Cadran
 Zifferblatt
 Dial

3¾ x 6'''

Issued	13 Dez 2006	cw
Modified	15.Dez.2006 ÄA ----	cm
Released	YES	
Tolerance	+/- 20 µm	
Scale	5 : 1 (A4V)	

RONDA

1032

Sous réserve de modifications
 Aenderungen vorbehalten
 Modifications reserved

No. 5010.449 06

Ajustement aiguille des heures
Stundenzeigerpassung
Hour hand fitting

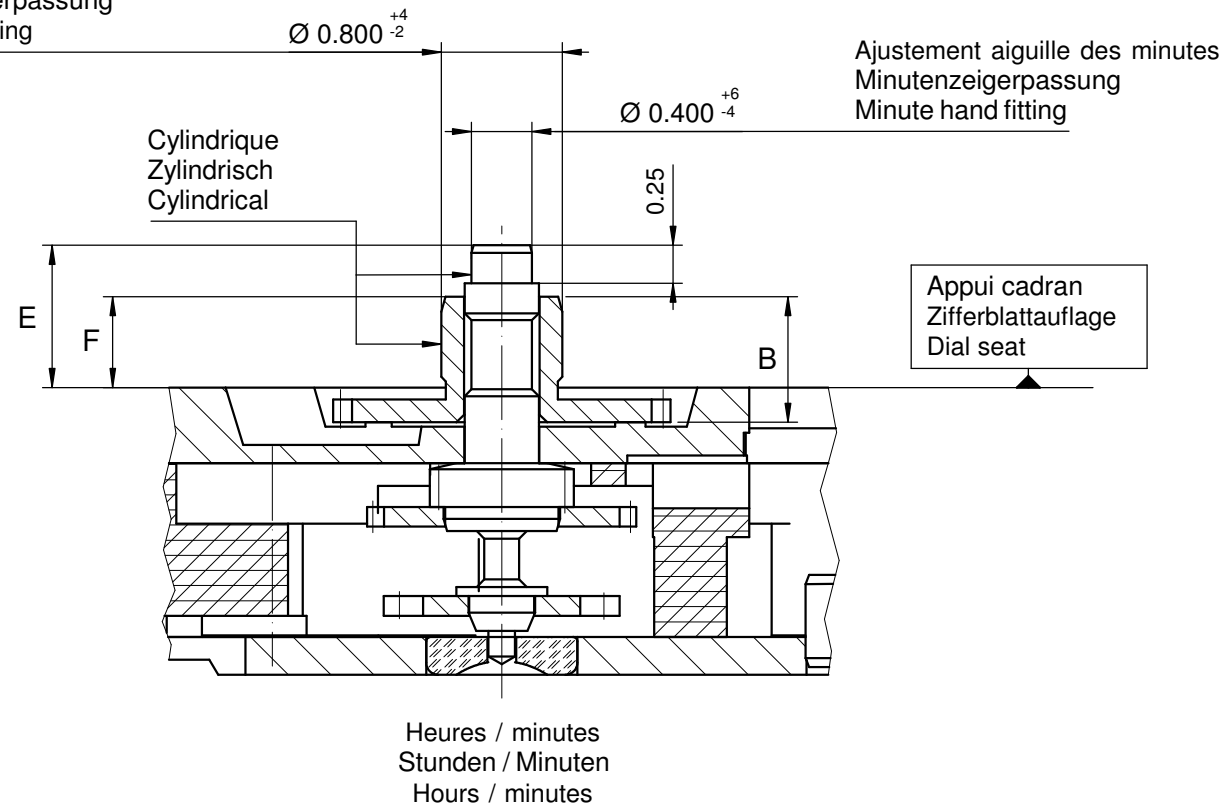

Aiguillage no. Zeigerwerkhöhe Nr. Hand fitting height No	Dépassement Höhe über Zifferblattaufgabe Height over dial seat			Longueur Länge Length		Epaisseur max. (peinture comprise) Max. Dicke (inkl. Farbe) Max. thickness (paint included)			
	Chaussée Minutenrohr Cannon-pinion	Roue des heures Stundenrad Hour wheel		Roue des heures Stundenrad Hour wheel		Cadran Zifferblatt Dial		Aiguilles Zeiger Hands	
						Sous l'aiguille des minutes Unter Minutenzeiger Under minute hand	Sous l'aiguille des heures Unter Stundenzeiger Under hour hand		
E	F		B						
0	0.94	0.60		0.83		0.50	0.30		0.15
1	1.14	0.80		1.03		0.70	0.50		0.15
2	1.44	1.10		1.33		1.00	0.80		0.15
3	1.84	1.50		1.73		1.40	1.20		0.15

	Aig. des minutes Minutenzeiger Minute hand	Aig. des heures Stundenzeiger Hour hand	Lors de la pose d'aiguilles, le mouvement doit être soutenu. Beim Zeigersetzen muss das Werk abgestützt werden. The movement needs to be supported for hand setting.
mg max.	30	30	Masse / Masse / Weight *
µNm max.	0.12	0.12	Balourd / Unwucht / Unbalance *
gmm ² max.	-	-	Inertie / Massenträgheit / Inertia *
N max.	40	40	Force de chassage / Aufpresskraft / Force

Sous réserve de toutes modifications

Aenderungen vorbehalten

All modifications reserved

Aiguillages Zeigerwerkhöhen Hand fitting heights		3 3/4 x 6'''		Issued	02 Feb 2005	fl
				Modified	18 Feb 2011 ÄA 10340	ps
				Released	Yes	
				Tolerance	µm	
				Scale	20 : 1 (A3H)	
RONDA	1032	Sous réserve de modifications Aenderungen vorbehalten Modifications reserved				
		No.	3316.093	04		

* En cas de données différentes, veuillez contacter le service après-vente

* Bei abweichenden Werten, bitte technischen Kundendienst anfragen

* In case of different values, please contact the customer service

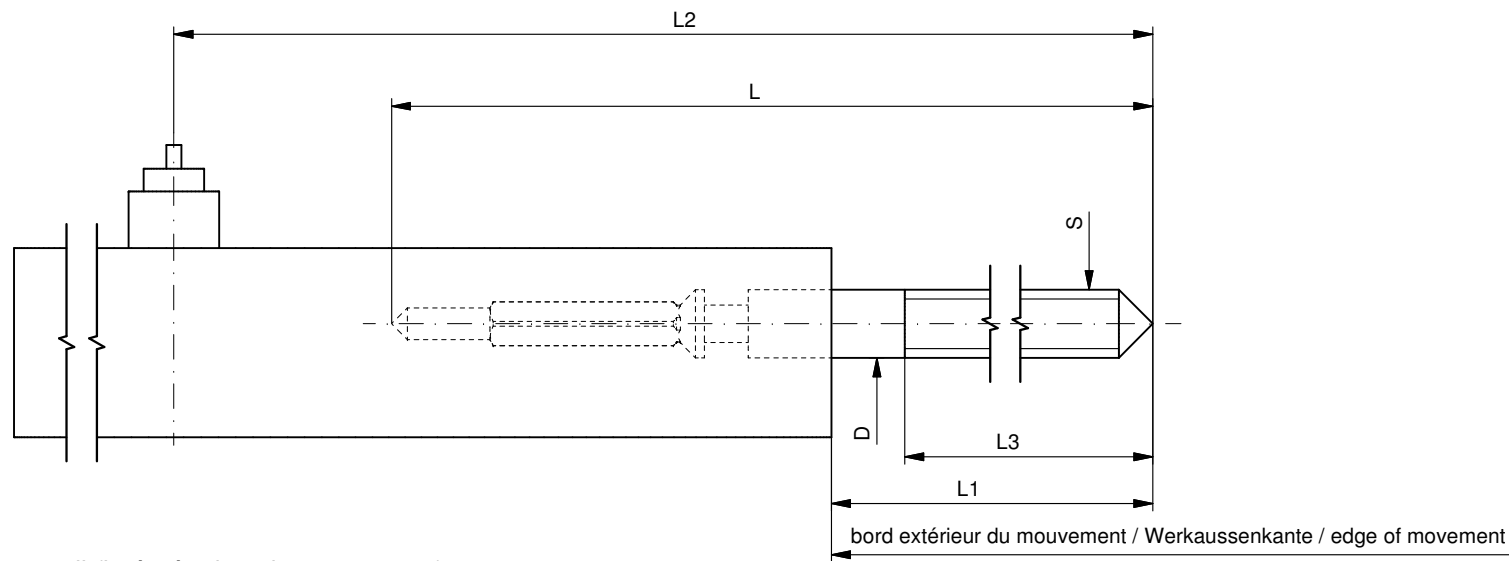

Tige de travail (intégrée dans le mouvement)
 Arbeitstellwelle (im Werk eingebaut)
 Working stem (implemented in the movement)

No. d'article Artikelnummer Part number	L	L1	L2	L3	S	D
3000.142.CO	16.95	13.37	17.87	13.45	0.70	0.70

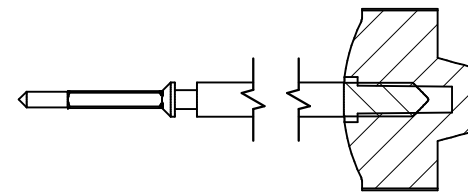

Couleur de la couronne Kronenfarbe Crown color	rose rosa pink
Code	UN 3031

Tige (normale) / Stellwelle (normal) / Stem (normal)

No. d'article Artikelnummer Part number	L	L1	L2	L3	S	D
3000.142	16.95	13.37	17.87	13.45	0.70	0.70
3000.146	16.95	13.37	17.87	13.25	0.80	0.70
3000.175	16.95	13.37	17.87	13.25	0.90	0.70
3000.184	20.00	16.42	20.92	16.50	0.70	0.70

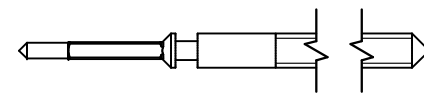

Couronne normale
 Normale Krone
 Normal crown

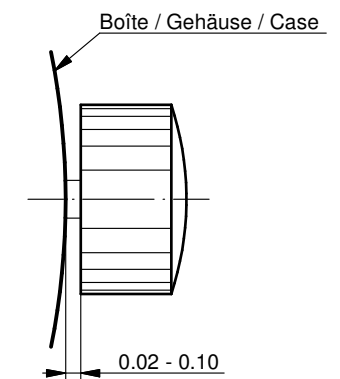

Couronne vissée
 Geschraubte Krone
 Screwed crown

Force ⇄ min. Kraft ⇄ min. Force ⇄ min.	10 N
Force ⇄ max. Kraft ⇄ max. Force ⇄ max.	15 N

Rallonge de tige / Stellwelle Verlängerung / Stem extension

No. d'article Artikelnummer Part number	L4	L5 (min)	L6	S1	S2	D1
3000.040	12.00	1.90	2.60	0.90	0.90	1.35
3000.046	12.00	1.90	2.60	0.70	0.70	1.00

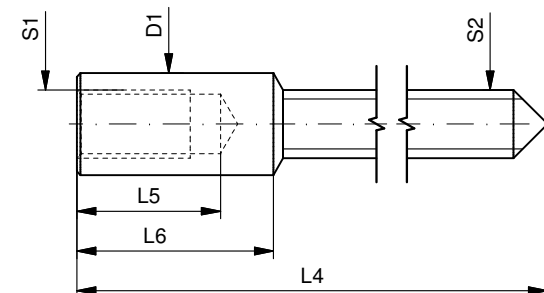

Tige (dimensions / forces)
 Stellwelle (Dimensionen / Kräfte)
 Stem (dimensions / forces)

RONDA 1032

Issued	30 Aug 2012	ds5222
Modified	17 Mär 2017 ÄA 34582	mg5224
Released	YES	
Tolerance	---	
Scale	10:1 (A3)	

Sous réserve de modifications
 Änderungen vorbehalten
 Modifications reserved

No.	5030.011	02
-----	----------	----



3 3/4" x 6"



Cal. 1032

Funktionen

Fonctions

Functions

Kaliber	Stellwellenpos.	Funktionen
Calibre	Pos. de tige	Fonctions
Caliber	Stem position	Functions
1032	1	Normale Position / Position normale / Running position
	2	Zeiger stellen Mise à l'heure Hand setting

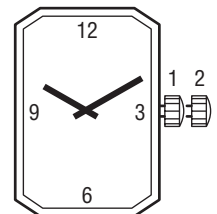

Batterie

Pile

Battery

Kaliber	Batterie	Spannung	Artikelnummer RONDA
Calibre	Pile	Voltage	Numero d'article RONDA
Caliber	Battery	Tension	Part number RONDA
1032	317/SR516SW	1.55 V	3600.019.HGF

3 3/4 x 6''' 1032

Cal. 1032 Werkseite / Côté mouvement / Movement side			
Plan no.	Bestandteile	Fournitures	Spare Parts
2000.469.G	Werkplatte	Platine	Main plate
2020.118.G.M01	Räderwerkbrücke	Pont rouge	Train w. bridge
3000.142	Stellwelle	Tige	Stem
3001.059.FI	Kupplungstrieb	Pignon coulant	Sliding pinion
3004.128.FI	Zeigerstellrad	Renvoi	Setting wheel
3007.046.CO	Wechselrad	Minuterie	Minute wheel
3015.043	Wippe	Bascule	Yoke
3017.040	Stellhebel	Tirette	Setting lever
3122.051.CO	Kleinbodenrad	Roue moyenne	Third wheel
3147.035.CO	Zwischenrad	Roue intermed.	Intermed. wheel
3305.231.CO	Minutenrohr	Chaussée	Cannon pinion
3600.019.HGF	Batterie	Pile	Battery
3601.061.G	Batteriehalter(+)	Bride pile(+)	Battery clamp(+)
3602.015	Batteriekontakt(-)	Bride contact(-)	Battery contact(-)
3603.041	Kunstst.-Zw.-teil	Potence plast.	Set. mech. cover
3603.042	Batt.Isolation	Isolateur pile	Battery insulation
1)	Modul	Module	Module
3621.058.RK	Spule	Bobine	Coil
3622.017	Stator	Stator	Stator
2)	Spulenschutz	Protection bobine	Coil protection
3715.053.RK	Rotor	Rotor	Rotor
4000.268	Schraube	Vis	Screw
4010.102	Schraube	Vis	Screw
4010.141	Schraube	Vis	Screw
4301.103	Stift für Potence	Pivot potence	Pilar

Cal. 1032 Zifferblattseite / Côté cadran / Dial side			
Plan No.	Bestandteile	Fournitures	Spare Parts
3301.189	Stundenrad	Canon	Hour wheel
3315.011	Spreifeder	Clinquant	Washer

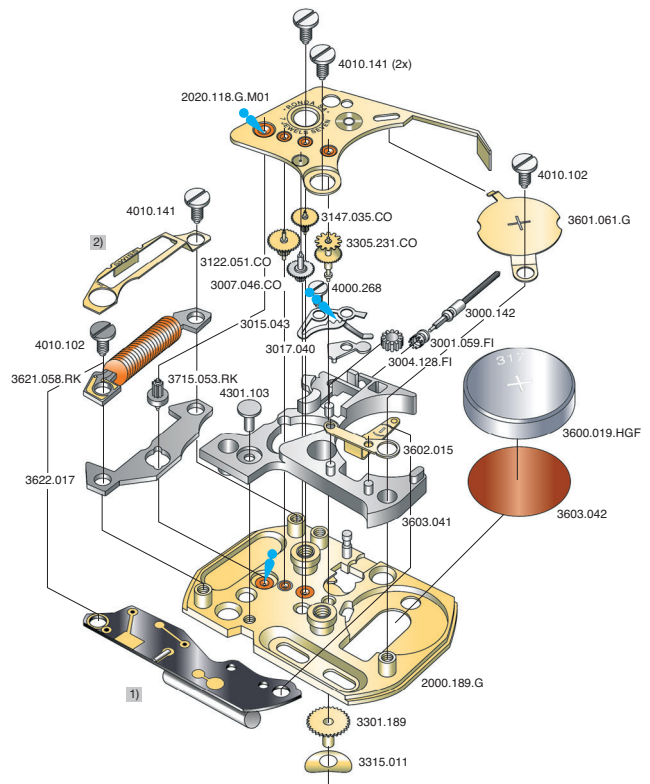

••••• Düninflüssiges Oel, z.B. Moebius 9030
 ••••• Fett, z.B. Moebius, Microgliss D5, Jisma 124

		1032 SWISS MADE	1032 SWISS PARTS
1)	Modul Module Module	3612.155	
2)	Spulenschutz Protection bobine Coil protection	3651.024.G.M01 3651.024.M02	

Elektr. Messungen

Contrôles électriques

Electrical checking

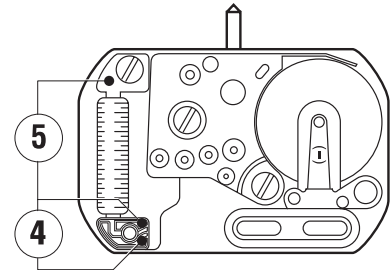
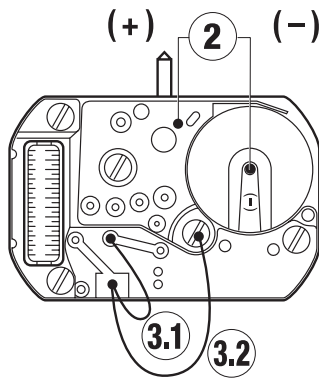
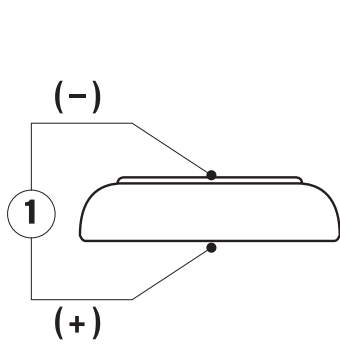

Kaliber Calibre Caliber	Pos. Pos. Pos.	Einheit Unité Unit	Messwerte Valeurs mesurées Measured values	Kontrolle Contrôle Check	Bemerkungen Remarques Remarks	
1032	1	V	1,55	Batterie-Spannung Tension de la pile Battery voltage	Batterie herausnehmen und messen Enlever et mesurer la pile Remove battery for measuring	
1032	2	µA	0,28 < 0,38 ~ 3,30	Stromverbrauch Consom. de courant Power consumption	Ohne Batterie, mit externer Speisung 1,55V Sans pile, avec alimentation externe de 1,55V Without battery, with ext. power supply 1,55V	
1032	2	V	1,35 V	Funktionskontrolle bei Minimalspannung Contrôle de fonctionnement à tension min. Operation with lowest possible voltage	Ohne Batterie, mit externer Speisung unter Kontaktierung von Punkt 3.1 (Acc.) Sans pile, alimentation externe en relayant le point 3.1 (Acc.) Without battery, with external power supply by contacting point 3.1 (Acc.)	
1032	3.1	Hz	32 Hz	Motorimpuls beschleunigt Impulsions de moteur accélérées Accelerated motor pulses	Mit Batterie oder externer Speisung 1,55V Avec pile ou alimentation externe de 1,55V With battery or ext. power supply of 1,55V	
1032	3.2	Hz	0	Motorimpuls unterbrochen Impulsions de moteur interrompues Interrupted motor pulses	Mit Batterie oder externer Speisung 1,55V Avec pile ou alimentation externe de 1,55V With battery or ext. power supply of 1,55V	
1032	4	K	1,80–1,95	Spulenwiderstand Résistance de la bobine Coil resistance	Ohne Batterie Sans pile Without battery	
1032	4	K	∞	Spulenisolation Isolation de la bobine Coil insulation	Ohne Batterie Sans pile Without battery	
1032		Sek. / Monat sec. / mois sec. / month		- 10/+ 20	Induktivsonde 60 Sekunden Senseur inductif 60 secondes Inductive sensor 60 seconds	Mit Batterie Avec pile With battery

Einschalen / Werkzeuge

Emboîtage / outils

Casing / tools

Nr. H 1032.1A



Zeigersetzen

Maximale Aufpresskraft:

– Stunden und Minutenzeiger: max. 40N

Beim Zeigersetzen muss das Werk abgestützt werden.

Poser les aiguilles

Force de chassage maximale:

– Aiguilles des heure et des minutes: max. 40N

Lors de la pose d'aiguilles, le mouvement doit être soutenu.

Hand setting

Maximal force:

– Hour and minute hands: max. 40N

The movement needs to be supported for hand setting.

Nr. H 1032.1T



Stellwelle entfernen

Beim Entfernen der Stellwelle muss sich die Stellwelle in Position 1 (gedrückt) befinden, bevor auf den Winkelhebel gedrückt wird.

Enlever la tige

En enlevant la tige, la tige doit se trouver en position 1 (poussée), avant de pousser sur la tirette.

Stem removal

For removal of the stem, the stem must be pushed into position 1 (pressed in) prior to apply pressure to the setting lever.